

FABA

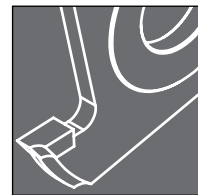
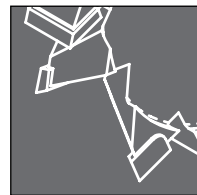
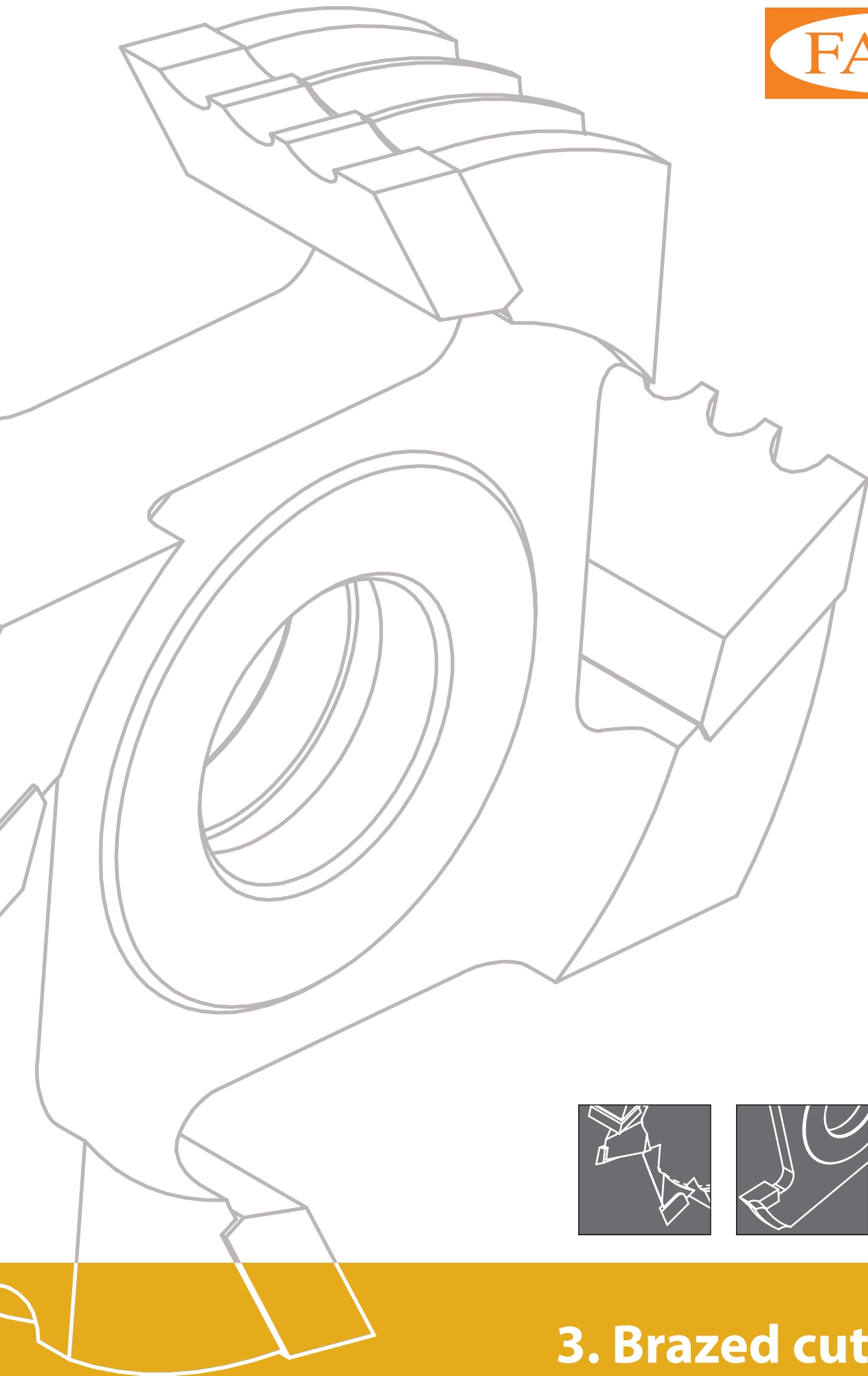

3. Brazed cutters

Brazed cutters

Brazed cutters with high speed steel tips (HSS) designed for professional machining of solid soft wood and brazed cutters with carbide tips (HM) designed for professional machining of solid soft and hard wood, glued wood and other wood-based materials. They are used for machining flat surfaces, grooves, rebates and decorative boards with complex shapes.

Cutters and sets of cutters are made from the highest quality high speed cutting steel in special heat treatment technology, which has been properly selected for the type of work, parameters and conditions prevailing during the machining, in order to guarantee proper work of the tools both in standard and extreme conditions.

All types of cutters are manufactured on modern CNC machines of world-renowned producers, which guarantee high accuracy and precision of the produced tools. The construction and production remain in accordance with all points of safety standard EN/PN-847-1 concerning tools for mechanical woodworking.

Brazed cutters chapter includes only examples of cutters and sets of cutters with basic dimensions.

Optionally, we offer cutters and sets with shear angle and optimized chip flow, mounted on hydro sleeves, designed for professional, very precise machining of solid wood and wood-based materials with feed speed up to 200 m/min. On request, we can suggest, design and manufacture a proper tool for the required type of work, material, parameters and conditions during machining. The production time of catalogue cutters or sets indicated with "+" as well as special tools made on client's request, in most cases does not take more than 10 working days.

Orders should include

- outer diameter (D) or diameters range,
- bore diameter (d),
- number of teeth (z) or spindle rotation speed and feed speed,
- type of machined material,
- profile drawing with dimensions or profile sample.



Contents

3. BRAZED CUTTERS

Pictograms	3.4
Cutters coding system	3.4
Tools for manual feed	3.5
Basic machining parameters	3.5
Rotation direction	3.5
3.1 Slotting cutters	3.6
3.2 Straight cutters with spurs	3.13
3.3 Profile cutters	3.15
3.4 Angle cutters	3.24
3.5 Special cutters	3.28
Sets of cutters	3.34
3.6 Sets for wainscots	3.35
3.7 Sets for floor board	3.37
3.8 Sets for parquet	3.39
3.9 Sets of profile cutters	3.40
3.10 Sets for garden programme	3.48
3.11 Sets with hydro clamping	3.51

Pictograms

3



solid dry softwood



solid dry hardwood



chipboard



glued wood



MDF



carbide



high-speed cutting steel



hydro clamping



quiet and steady work



flat surfaces



rebating



grooving



edge machining



profiling



resin pockets machining



tongue-groove joint



mechanical feed



manual feed

- available / stock product
- + production time 9–15 working days.

Cutters coding system

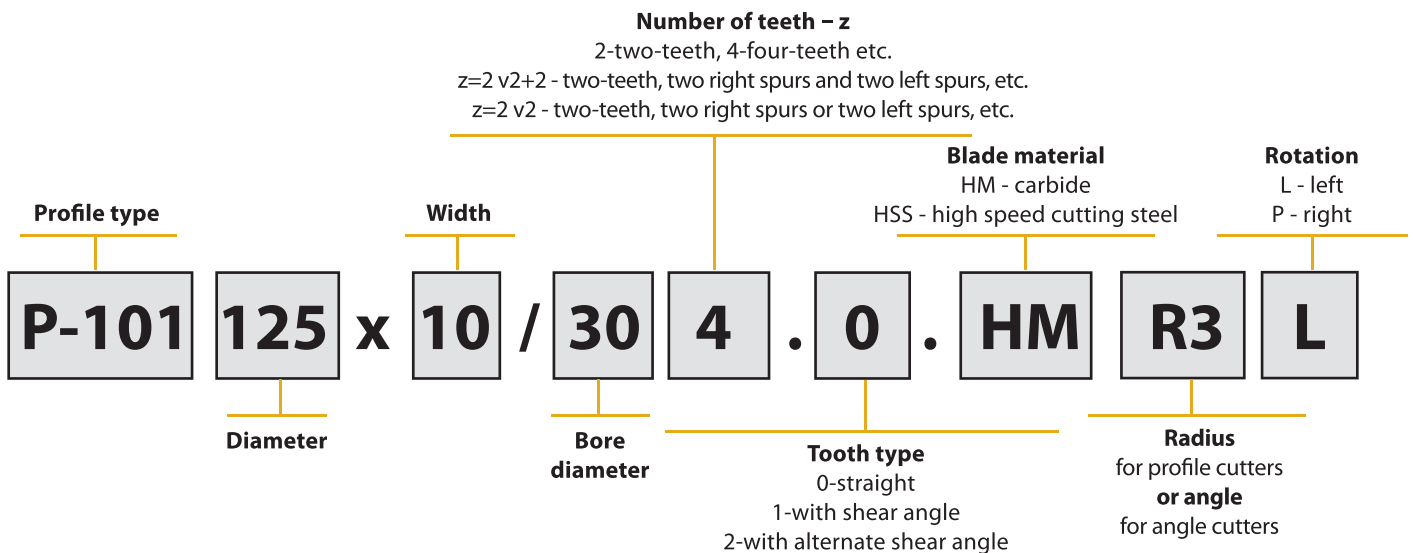

Tools for manual feed – with lower kick back force

As standard, FABA tools are offered for machines with mechanical feed (MEC).

On request, we suggest, design and produce also tools for machines with manual feed (MAN). Special construction of tools for manual feed guarantees lower kick back force.

1. MAN type tools should work within limited cutting speed range $V = 40 \div 70$ m/s.
2. Blade projection $c < 1,1$ mm.
3. Prices of MAN type tools are calculated as follows:
 - price of two-teeth MAN type tool equals to price of four-teeth MEC (mechanical) type tool
 - price of three-teeth MAN type tool equals to price of six-teeth MEC (mechanical) type tool

Manual feed

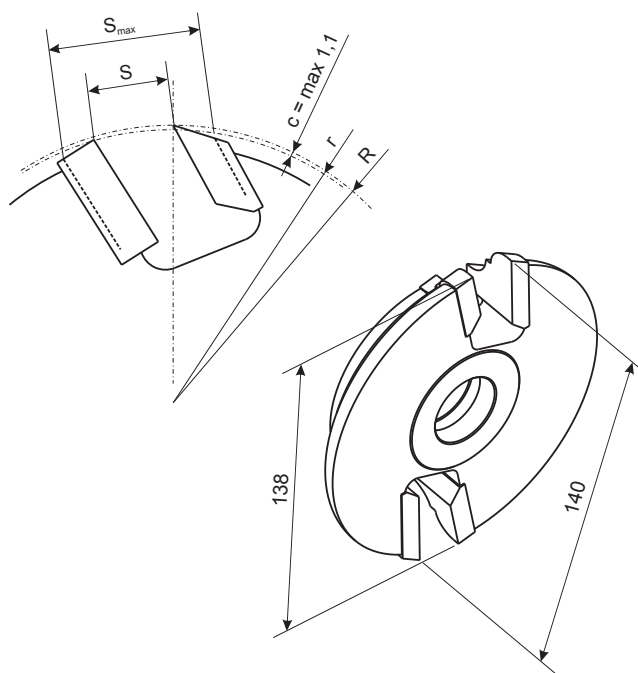

3

Basic cutting parameters

Cutting speed V_c

$$V_c = \frac{D \times n \times \pi}{60\,000} \text{ [m/s]}$$

- D - tool diameter [mm]
- n - rotation speed [1/min]
- p_z - feed per tooth [mm]
- p_{min} - feed per minute [m/min]
- z - number of teeth
- $\pi = 3,14$

Feed p_{min} / p_z

$$p_{min} \text{ [m/min]} \longleftrightarrow p_z \text{ [mm/tooth]}$$

$$p_{min} = \frac{p_z \times n \times z}{1\,000}$$

$$p_z = \frac{p_{min} \times 1\,000}{n \times z}$$

Rotation direction

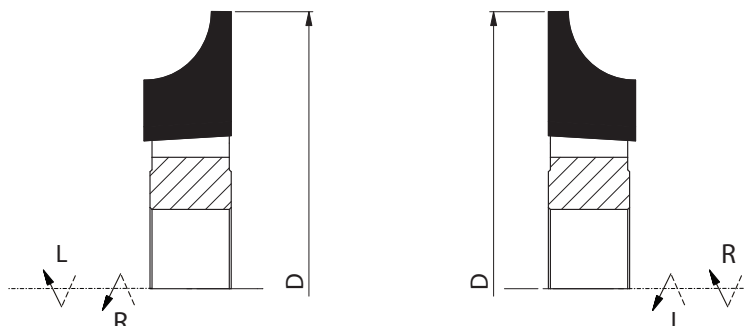

3110 4.0

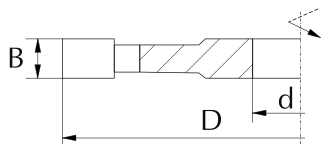
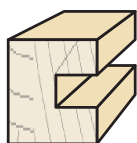
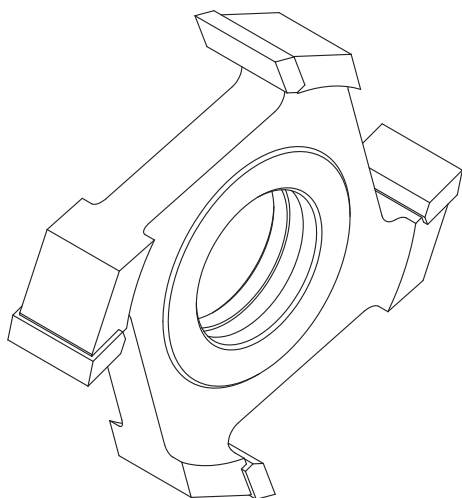

Brazed slotting cutter, type **3110** with four cutting teeth, designed for professional cutting of wood and wood-based materials such as chipboard, MDF and others. Compact construction guarantees precise positioning on the spindle. Cutting edge is parallel to the tool's axis.

Type of work: flat surfaces, rebates and grooves with dimension equal to cutter's width.

Material:

HSS solid softwood

HM solid hardwood, glued wood, chipboard, MDF

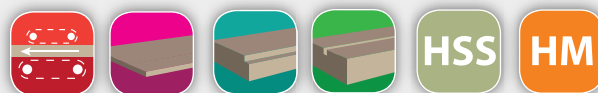

D n _{max} d _{max}	63 12000 25		80 9000 30		100 9000 40		125 9000 40		140 6000 60		160 6000 60		180 6000 60		200 6000 60	
	B mm	HSS	HM	HSS	HM	HSS	HM	HSS	HM	HSS	HM	HSS	HM	HSS	HM	
6	+	+	+	+	+	+	+	+	+	+	+	+	+	+	+	
8	+	+	+	+	+	+	+	+	+	+	+	+	+	+	+	
10	+	+	+	+	+	+	+	+	+	+	+	+	+	+	+	
12	+	+	+	+	+	+	+	+	+	+	+	+	+	+	+	
14	+	+	+	+	+	+	+	+	+	+	+	+	+	+	+	
16	+	+	+	+	+	+	+	+	+	+	+	+	+	+	+	
18	+	+	+	+	+	+	+	+	+	+	+	+	+	+	+	
20	+	+	+	+	+	+	+	+	+	+	+	+	+	+	+	
25	+	+	+	+	+	+	+	+	+	+	+	+	+	+	+	
30	+	+	+	+	+	+	+	+	+	+	+	+	+	+	+	
35	+	+	+	+	+	+	+	+	+	+	+	+	+	+	+	
40	+	+	+	+	+	+	+	+	+	+	+	+	+	+	+	
45	+	+	+	+	+	+	+	+	+	+	+	+	+	+	+	
50	+	+	+	+	+	+	+	+	+	+	+	+	+	+	+	
55	+	+	+	+	+	+	+	+	+	+	+	+	+	+	+	
60	+	+	+	+	+	+	+	+	+	+	+	+	+	+	+	

Brazen slotting cutter, type **3110** with six cutting teeth, designed for professional cutting of wood and wood-based materials such as chipboard, MDF and others.

Type of work: flat surfaces, rebates and grooves with dimension equal to cutter's width.

Material:

HSS solid softwood

HM solid hardwood, glued wood, chipboard, MDF

3110 6.0

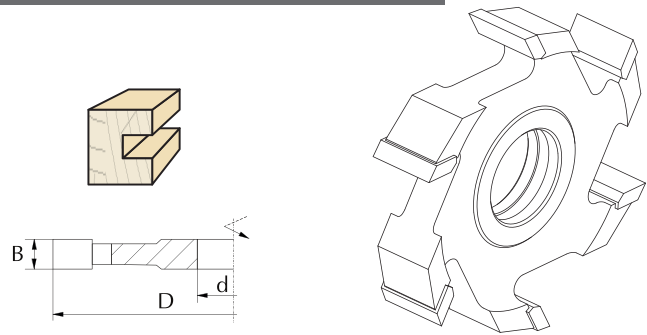

3

D n _{max} d _{max}	80 9000 30		100 9000 40		125 9000 40		140 6000 60		160 6000 60		180 6000 60		200 6000 60	
	B mm	HSS	HM	HSS	HM	HSS	HM	HSS	HM	HSS	HM	HSS	HM	
6	+	+	+	+	+	+	+	+	+	+	+	+	+	
8	+	+	+	+	+	+	+	+	+	+	+	+	v	
10	+	+	+	+	+	+	+	+	+	+	+	+	+	
12	+	+	+	+	+	+	+	+	+	+	+	+	+	
14	+	+	+	+	+	+	+	+	+	+	+	+	+	
16	+	+	+	+	+	+	+	+	+	+	+	+	+	
18	+	+	+	+	+	+	+	+	+	+	+	+	+	
20	+	+	+	+	+	+	+	+	+	+	+	+	+	
25	+	+	+	+	+	+	+	+	+	+	+	+	+	
30	+	+	+	+	+	+	+	+	+	+	+	+	+	
35	+	+	+	+	+	+	+	+	+	+	+	+	+	
40	+	+	+	+	+	+	+	+	+	+	+	+	+	
45	+	+	+	+	+	+	+	+	+	+	+	+	+	
50	+	+	+	+	+	+	+	+	+	+	+	+	+	
55	+	+	+	+	+	+	+	+	+	+	+	+	+	
60	+	+	+	+	+	+	+	+	+	+	+	+	+	



Catalogue number	Type	D mm	B mm	d mm	z		
3110W080-0005	3110	80	40	30	6	HM	•
3110W080-0006	3110	80	45	30	6	HM	•
3110W080-0007	3110	80	50	30	6	HM	•
3110W125-0001	3110	125	10	30	6	HM	•
3110W125-0007	3110	125	12	30	6	HM	•
3110W125-0009	3110	125	14	30	6	HM	•
3110W125-0010	3110	125	16	30	6	HM	•
3110W125-0011	3110	125	18	30	6	HM	•
3110W125-0012	3110	125	20	30	6	HM	•
3110W125-0013	3110	125	25	30	6	HM	•
3110W125-0014	3110	125	30	30	6	HM	•
3110W125-0008	3110	125	35	30	6	HM	•
3110W125-0015	3110	125	40	30	6	HM	•
3110W125-0016	3110	125	45	30	6	HM	•

3110 6.2

Brazed slotting cutter, type **3110** with six cutting teeth and alternative shear angle designed for professional cutting of wood and wood-based materials such as chipboard, MDF and others. Alternative shear angle allows for high quality of the machined surface.

Type of work: flat surfaces, rebates and grooves with dimension equal to cutter's width.

Material:

-  solid softwood
-  solid hardwood, glued wood, chipboard, MDF

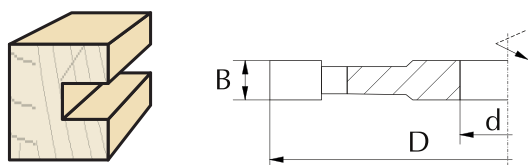
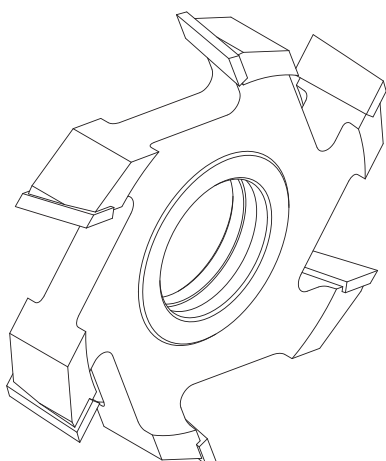

D n _{max} d _{max}	80 9000 30		100 9000 40		125 9000 40		140 6000 60		160 6000 60		180 6000 60		200 6000 60		
	B mm	HSS	HM	HSS	HM	HSS	HM	HSS	HM	HSS	HM	HSS	HM	HSS	HM
6		+	+	+	+	+	+	+	+	+	+	+	+	+	+
8		+	+	+	+	+	+	+	+	+	+	+	+	+	+
10		+	+	+	+	+	+	+	+	+	+	+	+	+	+
12		+	+	+	+	+	+	+	+	+	+	+	+	+	+
14		+	+	+	+	+	+	+	+	+	+	+	+	+	+
16		+	+	+	+	+	+	+	+	+	+	+	+	+	+
18		+	+	+	+	+	+	+	+	+	+	+	+	+	+
20		+	+	+	+	+	+	+	+	+	+	+	+	+	+
25		+	+	+	+	+	+	+	+	+	+	+	+	+	+
30		+	+	+	+	+	+	+	+	+	+	+	+	+	+
35		+	+	+	+	+	+	+	+	+	+	+	+	+	+
40		+	+	+	+	+	+	+	+	+	+	+	+	+	+
45		+	+	+	+	+	+	+	+	+	+	+	+	+	+
50		+	+	+	+	+	+	+	+	+	+	+	+	+	+
55		+	+	+	+	+	+	+	+	+	+	+	+	+	+
60		+	+	+	+	+	+	+	+	+	+	+	+	+	+

Brazen slotting cutter, type **3110** with eight cutting teeth designed for professional cutting of wood and wood-based materials such as chipboard, MDF and others. Large number of teeth allows for higher feed speed and guarantees optimal workload of the machine spindle.

Type of work: flat surfaces, rebates and grooves with dimension equal to cutter's width.

Material:

HSS solid softwood

HM solid hardwood, glued wood, chipboard, MDF

3110 8.0

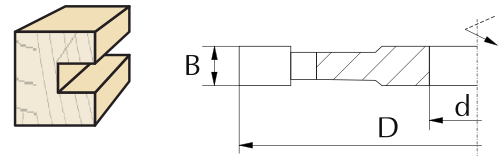
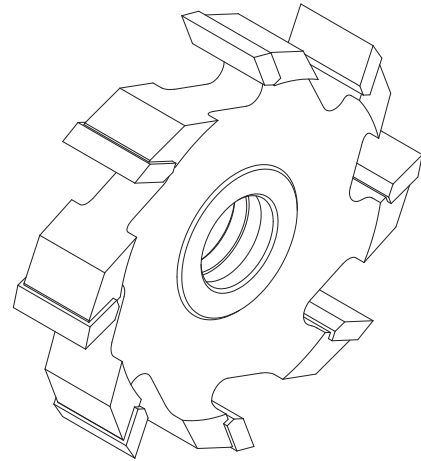

3



D n _{max} d _{max}	100 9000 40		125 9000 40		140 6000 40		160 6000 60		180 6000 60		200 6000 60		
	B mm	HSS	HM	HSS	HM	HSS	HM	HSS	HM	HSS	HM	HSS	HM
6		+	+	+	+	+	+	+	+	+	+	+	+
8		+	+	+	+	+	+	+	+	+	+	+	+
10		+	+	+	+	+	+	+	+	+	+	+	+
12		+	+	+	+	+	+	+	+	+	+	+	+
14		+	+	+	+	+	+	+	+	+	+	+	+
16		+	+	+	+	+	+	+	+	+	+	+	+
18		+	+	+	+	+	+	+	+	+	+	+	+
20		+	+	+	+	+	+	+	+	+	+	+	+
25		+	+	+	+	+	+	+	+	+	+	+	+
30		+	+	+	+	+	+	+	+	+	+	+	+
35		+	+	+	+	+	+	+	+	+	+	+	+
40		+	+	+	+	+	+	+	+	+	+	+	+
45		+	+	+	+	+	+	+	+	+	+	+	+
50		+	+	+	+	+	+	+	+	+	+	+	+
55		+	+	+	+	+	+	+	+	+	+	+	+
60		+	+	+	+	+	+	+	+	+	+	+	+

Catalogue number	Type	D mm	B mm	d mm	z	
3110W200-0433	3110	200	10	30	8	HM •
3110W200-0434	3110	200	12	30	8	HM •
3110W200-0438	3110	200	20	30	8	HM •

3110 8.2

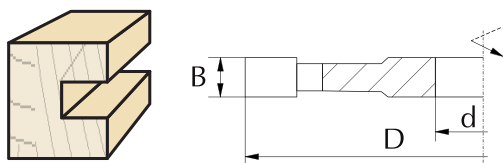
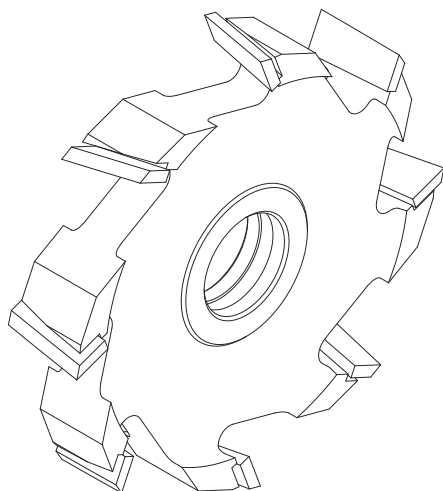

Brazed slotting cutter, type **3110** with eight cutting teeth and alternative shear angle designed for professional cutting of wood and wood-based materials such as chipboard, MDF and others. Alternative shear angle allows for high quality of the machined surface. Large number of teeth allows for higher feed speed and guarantees optimal workload of the machine spindle.

Alternative shear angle allows for high quality of the machined surface with very low energy consumption.

Type of work: flat surfaces, rebates and grooves with dimension equal to cutter's width.

Material:

- HSS solid softwood
- HM solid hardwood, glued wood, chipboard, MDF



D n _{max} d _{max}	125 9000 40		140 6000 40		160 6000 60		180 6000 60		200 6000 60	
	HSS	HM	HSS	HM	HSS	HM	HSS	HM	HSS	HM
6	+	+	+	+	+	+	+	+	+	+
8	+	+	+	+	+	+	+	+	+	+
10	+	+	+	+	+	+	+	+	+	+
12	+	+	+	+	+	+	+	+	+	+
14	+	+	+	+	+	+	+	+	+	+
16	+	+	+	+	+	+	+	+	+	+
18	+	+	+	+	+	+	+	+	+	+
20	+	+	+	+	+	+	+	+	+	+
25	+	+	+	+	+	+	+	+	+	+
30	+	+	+	+	+	+	+	+	+	+
35	+	+	+	+	+	+	+	+	+	+
40	+	+	+	+	+	+	+	+	+	+
45	+	+	+	+	+	+	+	+	+	+
50	+	+	+	+	+	+	+	+	+	+
55	+	+	+	+	+	+	+	+	+	+
60	+	+	+	+	+	+	+	+	+	+

3110 12.0

Brazed slotting cutter, type **3110** with twelve cutting teeth designed for professional cutting of wood and wood-based materials such as chipboard, MDF and others. Large number of teeth allows for higher feed speed and guarantees optimal workload of the machine spindle.

Type of work: flat surfaces, rebates and grooves with dimension equal to cutter's width.

Material:

HSS solid softwood

HM solid hardwood, glued wood, chipboard, MDF

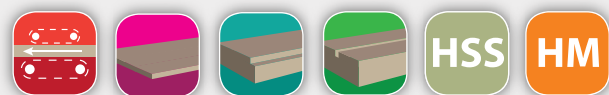
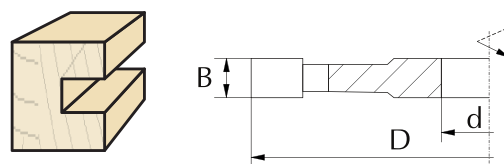
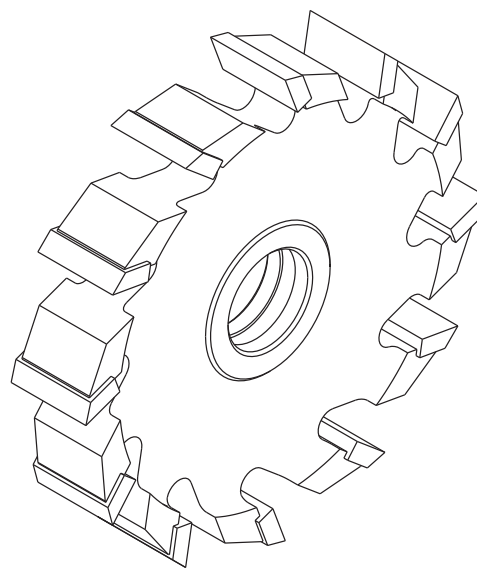

D n _{max} d _{max}	125 6000 40		140 6000 40		160 6000 60		180 6000 60		200 6000 60	
	HSS	HM	HSS	HM	HSS	HM	HSS	HM	HSS	HM
B mm										
6	+	+	+	+	+	+	+	+	+	+
8	+	+	+	+	+	+	+	+	+	+
10	+	+	+	+	+	+	+	+	+	+
12	+	+	+	+	+	+	+	+	+	+
14	+	+	+	+	+	+	+	+	+	+
16	+	+	+	+	+	+	+	+	+	+
18	+	+	+	+	+	+	+	+	+	+
20	+	+	+	+	+	+	+	+	+	+
25	+	+	+	+	+	+	+	+	+	+
30	+	+	+	+	+	+	+	+	+	+
35	+	+	+	+	+	+	+	+	+	+
40	+	+	+	+	+	+	+	+	+	+
45	+	+	+	+	+	+	+	+	+	+
50	+	+	+	+	+	+	+	+	+	+
55	+	+	+	+	+	+	+	+	+	+
60	+	+	+	+	+	+	+	+	+	+

3110 12.2

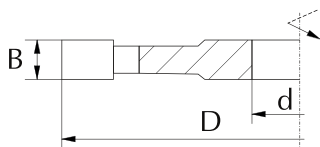
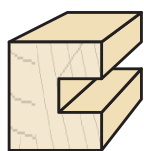
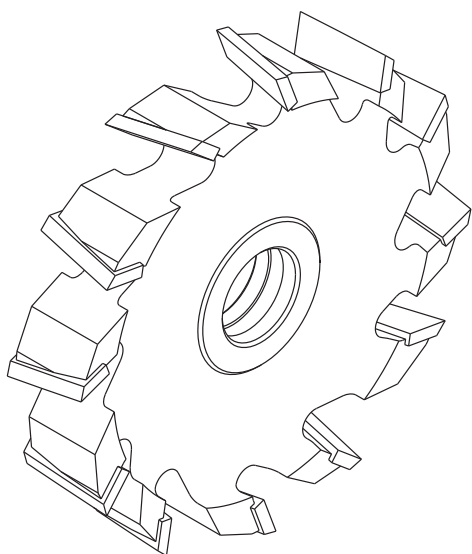

Brazen slotting cutter, type **3110** with twelve cutting teeth and alternative shear angle designed for professional cutting of wood and wood-based materials such as chipboard, MDF and others. Alternative shear angle allows for high quality of the machined surface. Large number of teeth allows for higher feed speed and guarantees optimal workload of the machine spindle.

Alternative shear angle allows for high quality of the machined surface with very low energy consumption.

Type of work: flat surfaces, rebates and grooves with dimension equal to cutter's width.

Material:

HSS solid softwood

HM solid hardwood, glued wood, chipboard, MDF



D n _{max} d _{max}	140 6000 40		160 6000 60		180 6000 60		200 6000 60		
	B mm	HSS	HM	HSS	HM	HSS	HM	HSS	HM
6		+	+	+	+	+	+	+	+
8		+	+	+	+	+	+	+	+
10		+	+	+	+	+	+	+	+
12		+	+	+	+	+	+	+	+
14		+	+	+	+	+	+	+	+
16		+	+	+	+	+	+	+	+
18		+	+	+	+	+	+	+	+
20		+	+	+	+	+	+	+	+
25		+	+	+	+	+	+	+	+
30		+	+	+	+	+	+	+	+
35		+	+	+	+	+	+	+	+
40		+	+	+	+	+	+	+	+
45		+	+	+	+	+	+	+	+
50		+	+	+	+	+	+	+	+
55		+	+	+	+	+	+	+	+
60		+	+	+	+	+	+	+	+

3110-1

Brazed slotting cutter, type **3110-1** with two cutting teeth and two left and two right spurs ($z=2$ v2+2) or four cutting teeth and four right and four left spurs ($z=4$ v4+4) allowing for precise grooving and rebating, designed for professional cutting of wood and wood-based materials such as chipboard, MDF and others.

Type of work: flat surfaces, rebates and grooves with dimension equal to cutter's width.

Material:

HSS solid softwood

HM solid hardwood, glued wood, chipboard, MDF

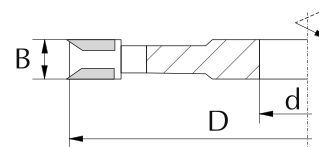
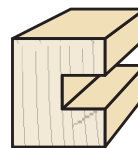

z=2 v2+2

D n _{max} d _{max}	100 9000 30		125 9000 35		140 6000 40		160 6000 40	
	HSS	HM	HSS	HM	HSS	HM	HSS	HM
4	+	+	+	+	+	+	+	+
5	+	+	+	+	+	+	+	+
6	+	+	+	+	+	+	+	+
8	+	+	+	+	+	+	+	+
10	+	+	+	+	+	+	+	+
12	+	+	+	+	+	+	+	+
14	+	+	+	+	+	+	+	+
16	+	+	+	+	+	+	+	+
18	+	+	+	+	+	+	+	+
20	+	+	+	+	+	+	+	+
25	+	+	+	+	+	+	+	+
30	+	+	+	+	+	+	+	+

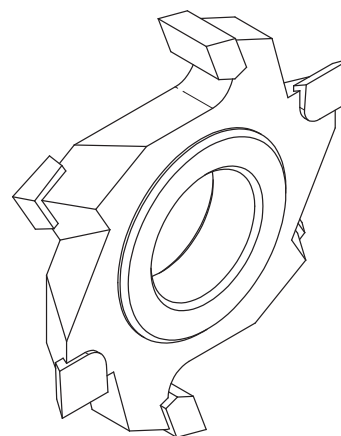

z=4 v4+4

D n _{max} d _{max}	160 6000 40		200 6000 40	
	HSS	HM	HSS	HM
6	+	+	+	+
8	+	+	+	+
10	+	+	+	+
12	+	+	+	+
14	+	+	+	+
16	+	+	+	+
18	+	+	+	+
20	+	+	+	+
25	+	+	+	+
30	+	+	+	+
35	+	+	+	+

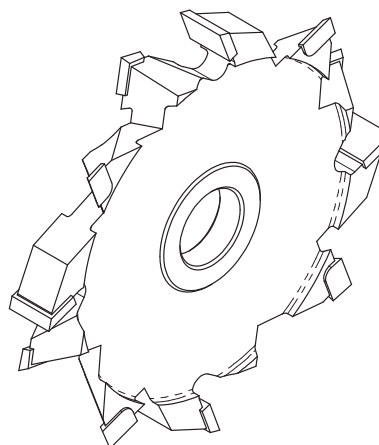

3110-2 R or L

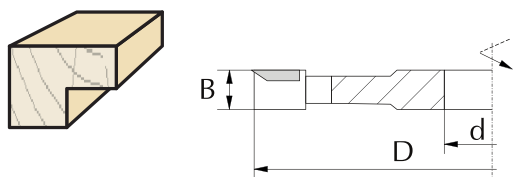

Brazed straight cutter, type **3110-2** with two cutting teeth and two left or right spurs ($z=2$ v_2) or four cutting teeth and four right or four left spurs ($z=4$ v_4) allowing for precise rebating, designed for professional cutting of wood and wood-based materials such as chipboard, MDF and others.

Type of work: precise machining of rebates and grooves with dimension smaller than to cutter's width.

Material:

HSS solid softwood

HM solid hardwood, glued wood, chipboard, MDF



z=2 v=2

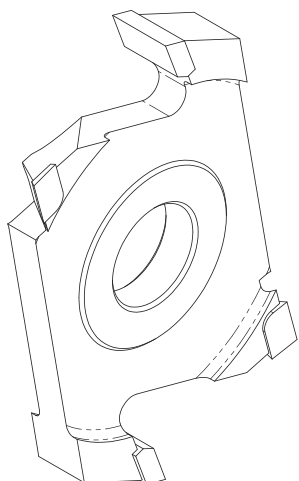

D n _{max} d _{max}	100		125		140		160		200	
	9000 30		9000 35		6000 40		6000 40		6000 40	
B mm	HSS	HM	HSS	HM	HSS	HM	HSS	HM	HSS	HM
6	+	+	+	+	+	+	+	+	+	+
8	+	+	+	+	+	+	+	+	+	+
10	+	+	+	+	+	+	+	+	+	+
12	+	+	+	+	+	+	+	+	+	+
14	+	+	+	+	+	+	+	+	+	+
16	+	+	+	+	+	+	+	+	+	+
18	+	+	+	+	+	+	+	+	+	+
20	+	+	+	+	+	+	+	+	+	+
25	+	+	+	+	+	+	+	+	+	+
30	+	+	+	+	+	+	+	+	+	+
35	+	+	+	+	+	+	+	+	+	+

z=4 v=4

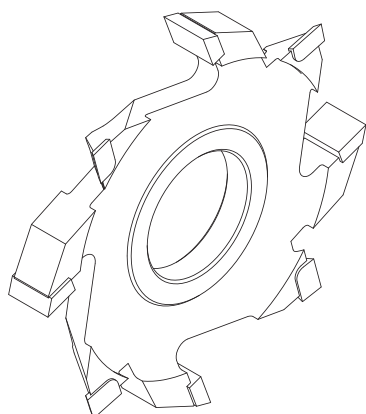

D n _{max} d _{max}	100		125		140		160		180		200	
	9000 30		9000 35		6000 40		6000 40		6000 40		6000 40	
B mm	HSS	HM	HSS	HM	HSS	HM	HSS	HM	HSS	HM	HSS	HM
6	+	+	+	+	+	+	+	+	+	+	+	+
8	+	+	+	+	+	+	+	+	+	+	+	+
10	+	+	+	+	+	+	+	+	+	+	+	+
12	+	+	+	+	+	+	+	+	+	+	+	+
14	+	+	+	+	+	+	+	+	+	+	+	+
16	+	+	+	+	+	+	+	+	+	+	+	+
18	+	+	+	+	+	+	+	+	+	+	+	+
20	+	+	+	+	+	+	+	+	+	+	+	+
25	+	+	+	+	+	+	+	+	+	+	+	+
30	+	+	+	+	+	+	+	+	+	+	+	+
35	+	+	+	+	+	+	+	+	+	+	+	+

Outer diameter of profile cutter (D) is tightly connected and depends on bore diameter (d) and profile depth (G_p). In order to precisely determine minimum diameter of the cutter (D_{min}) the following formula or diagram should be used:

$$D_{min} = 60 + d + 2 \times G_p$$

D_{min} - minimum diameter
 d - bore diameter
 G_p - profile depth

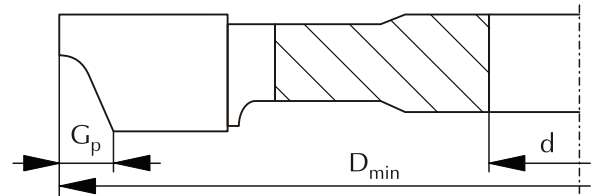

3

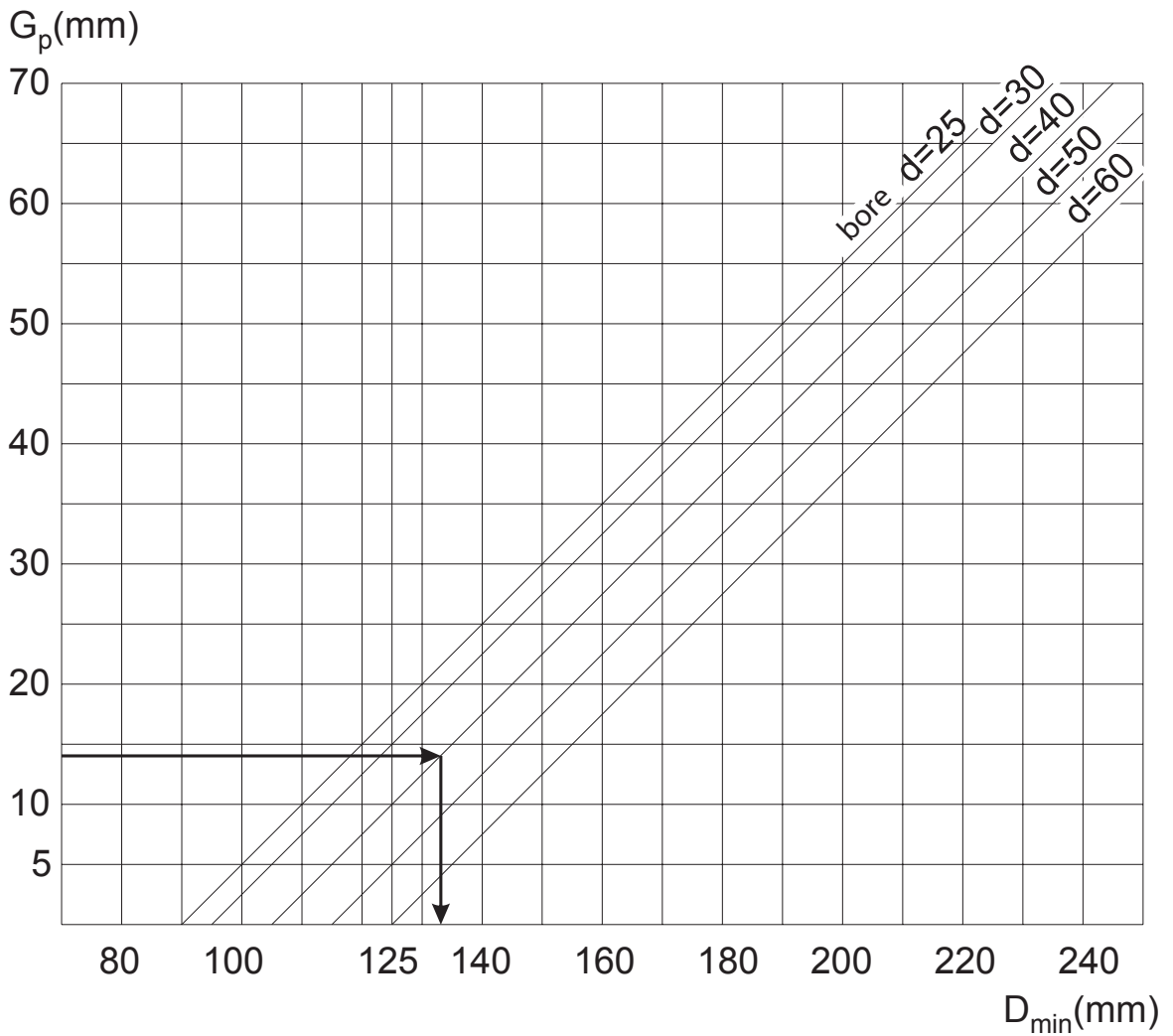

Example:

- d = 40 mm
- $G_p = 14$ mm
- $D_{min} = 60 + 40 + 2 \times 14 = 128$ mm

Round to closest typical bigger than D_{min} D = 130 mm.

P-101 4.0 R or L

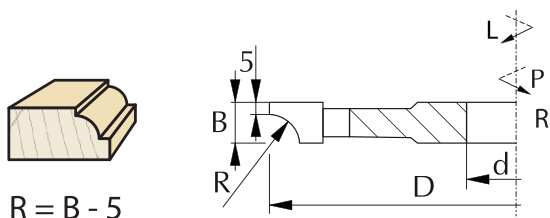
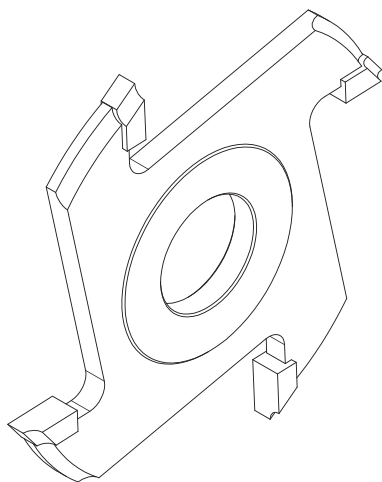

Braze profiled cutter, type **P-101** with four cutting teeth, designed for professional machining of wood and wood-based materials such as chipboard, MDF and others. The cutter is used for cutting quarter rounds with radius R.

Type of work: quarter rounds cutting.

Material:

- solid softwood
- solid hardwood, glued wood, chipboard, MDF



D n _{max} d _{max}	100 9000 30		125 9000 40		140 6000 50		160 6000 60	
	B mm	HSS	HM	HSS	HM	HSS	HM	HSS
8	+	+	+	+	+	+	+	+
9	+	+	+	+	+	+	+	+
10	+	+	+	+	+	+	+	+
11	+	+	+	+	+	+	+	+
13	+	+	+	+	+	+	+	+
15	+	+	+	+	+	+	+	+
17	+	+	+	+	+	+	+	+
20	+	+	+	+	+	+	+	+
25			+	+			+	+
30							+	+



Catalogue number right	Catalogue number left	Type	D mm	B mm	d mm	R mm	z	
P101W125P0009	P101W125L0009	P-101	125	8	30	3	4	HM •
P101S125P0016	P101S125L0016	P-101	125	10	30	5	4	HSS •
P101W125P0001	P101W125L0001	P-101	125	10	30	5	4	HM •
P101W125P0003	P101W125L0003	P-101	125	11	30	6	4	HM •
P101S125P0003	P101S125L0003	P-101	125	13	30	8	4	HSS •
P101W125P0004	P101W125L0004	P-101	125	13	30	8	4	HM •
P101S125P0005	P101S125L0005	P-101	125	15	30	10	4	HSS •
P101W125P0005	P101W125L0005	P-101	125	15	30	10	4	HM •
P101W125P0006	P101W125L0006	P-101	125	17	30	12	4	HM •
P101S125P0004	P101S125L0004	P-101	125	20	30	15	4	HSS •
P101W125P0007	P101W125L0007	P-101	125	20	30	15	4	HM •
P101S125P0001	P101S125L0001	P-101	125	25	30	20	4	HSS •
P101W125P0008	P101W125L0008	P-101	125	25	30	20	4	HM •
P101S140P0004	P101S140L0004	P-101	140	30	30	25	4	HSS •
P101W140P0007	P101W140L0007	P-101	140	30	30	25	4	HM •

Profile cutter diameter (D) may change - more information on page 3.15

Brazed profiled cutter, type **P-102** or **P-103** with four cutting teeth, designed for professional machining of wood and wood-based materials such as chipboard, MDF and others. The cutter is used for edge rounding with radius R according to client's request.

Material:

HSS solid softwood

HM solid hardwood, glued wood, chipboard, MDF



Type of work: edge rounding

P-102 4.0 R or L

D n _{max} d _{max}	100 9000 30		125 9000 40		140 6000 50		160 6000 60	
	HSS	HM	HSS	HM	HSS	HM	HSS	HM
B mm								
10	+	+	+	+	+	+	+	+
15	+	+	+	+	+	+	+	+
20	+	+	+	+	+	+	+	+
25	+	+	+	+	+	+	+	+
30	+	+	+	+	+	+	+	+
35	+	+	+	+	+	+	+	+
40	+	+	+	+	+	+	+	+
45	+	+	+	+	+	+	+	+
50	+	+	+	+	+	+	+	+

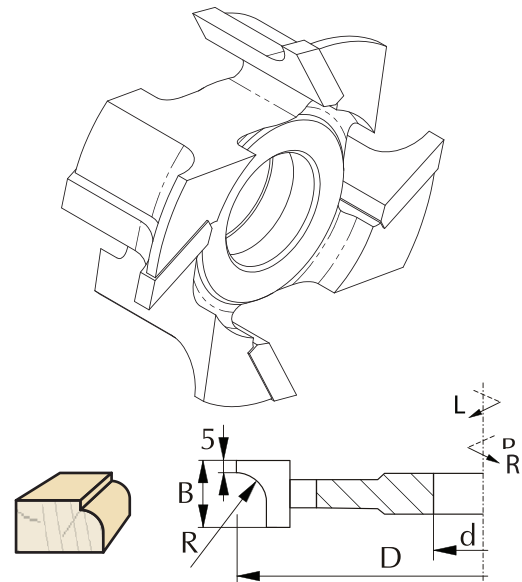

Type of work: two-sided edge rounding

P-103 4.0

D n _{max} d _{max}	100 9000 30		125 9000 40		140 6000 50	
	HSS	HM	HSS	HM	HSS	HM
B mm						
25	+	+	+	+	+	+
30	+	+	+	+	+	+
35	+	+	+	+	+	+
40	+	+	+	+	+	+
45	+	+	+	+	+	+
50	+	+	+	+	+	+

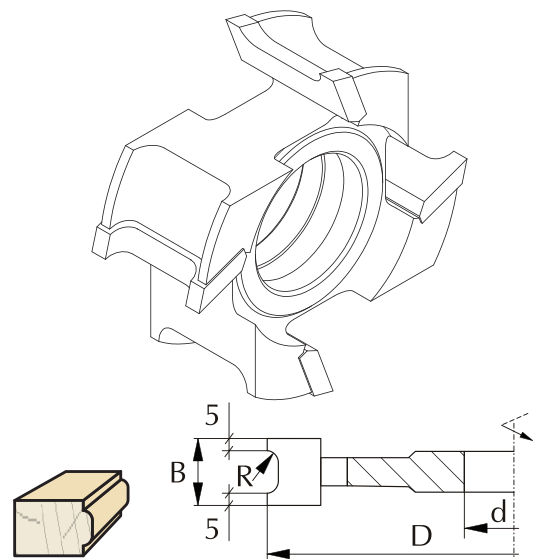

Profile cutter diameter (D) may change - more information on page 3.15

P-105 4.0

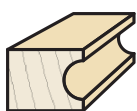
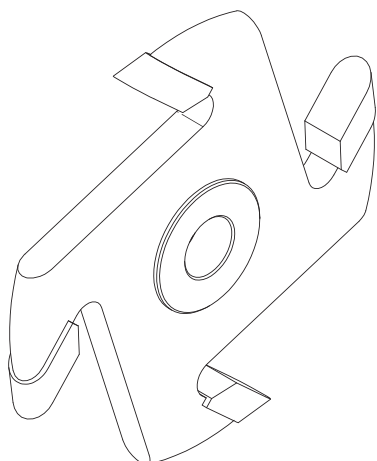

$B = 2 \times R$

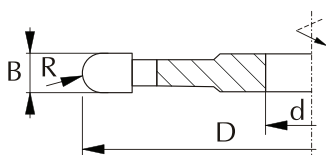

Brazed profiled cutter, type **P-105** with four cutting teeth, designed for professional machining of wood and wood-based materials such as chipboard, MDF and others. The cutter is used for grooving semi-circles with radius R according to client's request.

Type of work: grooving semi-circles with radius R.

Material:

HSS solid softwood

HM solid hardwood, glued wood, chipboard, MDF



D n d _{max} d _{max}			100 9000 30		125 9000 40		140 6000 50		160 6000 60	
	B mm	R mm	HSS	HM	HSS	HM	HSS	HM	HSS	HM
6	3		+	+	+	+	+	+	+	+
8	4		+	+	+	+	+	+	+	+
10	5		+	+	+	+	+	+	+	+
12	6		+	+	+	+	+	+	+	+
16	8		+	+	+	+	+	+	+	+
20	10		+	+	+	+	+	+	+	+
24	12		+	+	+	+	+	+	+	+
30	15		+	+	+	+	+	+	+	+
40	20				+	+	+	+	+	+
50	25						+	+	+	+

Catalogue number	Type	D mm	B mm	d mm	R mm	z		
P105W125-0001	P-105	125	8	30	4	4	HM	•
P105W125-0002	P-105	125	10	30	5	4	HM	•
P105W125-0003	P-105	125	12	30	6	4	HM	•
P105W125-0004	P-105	125	16	30	8	4	HM	•
P105W125-0005	P-105	125	20	30	10	4	HM	•
P105W125-0006	P-105	125	24	30	12	4	HM	•
P105W125-0007	P-105	125	30	30	15	4	HM	•

Profile cutter diameter (D) may change - more information on page 3.15

Brazen profiled cutter, type **P-106** with four cutting teeth, designed for professional machining of wood and wood-based materials such as chipboard, MDF and others. The cutter is used for grooving quarter-circles with radius R according to client's request.

Type of work: grooving quarter-circles with radius R.

Material:

HSS solid softwood

HM solid hardwood, glued wood, chipboard, MDF

P-106 4.0 R or L

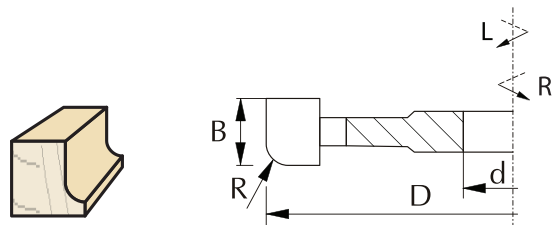
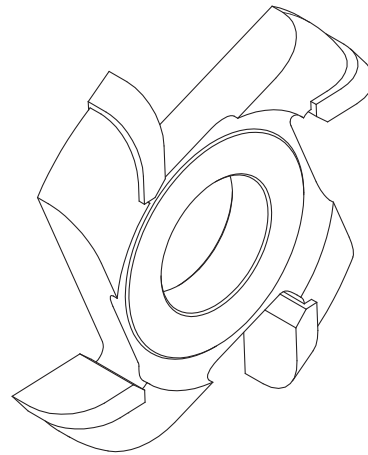

D n _{max} d _{max}	100 9000 30		125 9000 40		140 6000 50		
	B mm	HSS	HM	HSS	HM	HSS	HM
10		+	+	+	+	+	+
15		+	+	+	+	+	+
20		+	+	+	+	+	+
25		+	+	+	+	+	+
30		+	+	+	+	+	+
35		+	+	+	+	+	+
40		+	+	+	+	+	+

Profile cutter diameter (D) may change - more information on page 3.15

P-107 4.0

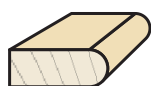
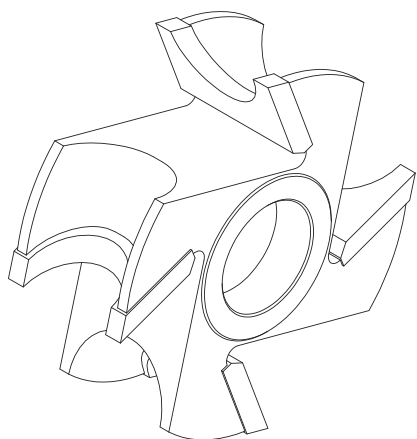

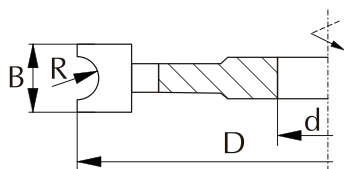

$$B = 2 \times R + 10$$



Brazed profiled cutter, type **P-107** with four cutting teeth, designed for professional machining of wood and wood-based materials such as chipboard, MDF and others. The cutter is used for making semi-rounds with radius R according to client's request.

Type of work: profiling semi-rounds with radius R.

Material:

-  solid softwood
-  solid hardwood, glued wood, chipboard, MDF

3



D n _{max} d _{max}			100 9000 30		125 9000 40		140 6000 50		160 6000 60	
	B mm	R mm	HSS	HM	HSS	HM	HSS	HM	HSS	HM
16	3		+	+	+	+	+	+	+	+
18	4		+	+	+	+	+	+	+	+
20	5		+	+	+	+	+	+	+	+
22	6		+	+	+	+	+	+	+	+
26	8		+	+	+	+	+	+	+	+
30	10		+	+	+	+	+	+	+	+
34	12		+	+	+	+	+	+	+	+
40	15				+	+	+	+	+	+
50	20				+	+			+	+
60	25								+	+

Catalogue number	Type	D mm	B mm	d mm	R mm	z		
P107W125-0003	P-107	125	22	30	6	4	HM	•
P107W125-0004	P-107	125	26	30	8	4	HM	•
P107W125-0005	P-107	125	30	30	10	4	HM	•
P107W125-0006	P-107	125	34	30	12	4	HM	•
P107W125-0007	P-107	125	40	30	15	4	HM	•
P107W125-0008	P-107	125	50	30	20	4	HM	•

Profile cutter diameter (D) may change - more information on page 3.15

Brazen profiled cutter, type **P-109** with four cutting teeth, designed for professional machining of wood and wood-based materials such as chipboard, MDF and others. The cutter is used for making multiple-dowels with radius R according to client's request.

Type of work: profiling multiple dowels with radius R.

Material:

HSS solid softwood

HM solid hardwood, glued wood, chipboard, MDF

P-109 4.0

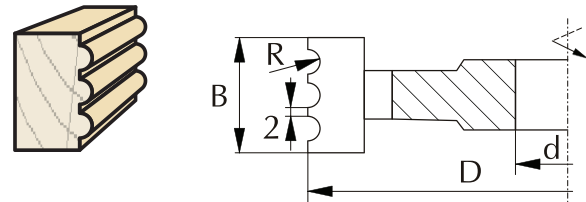
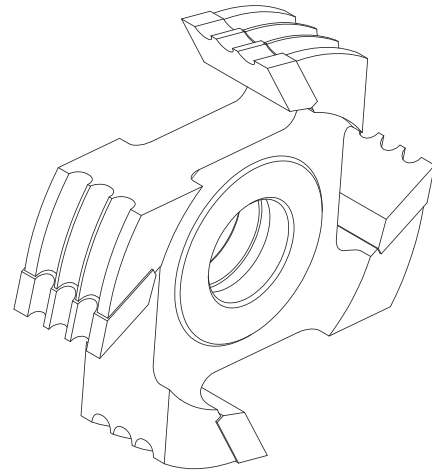

3



D mm	B mm	d _{max}	R mm	z		n _{max}	
125	32	40	3 x R3	4	HSS	9000	+
125	32	40	3 x R3	4	HM	9000	+
125	38	40	3 x R4	4	HSS	9000	+
125	38	40	3 x R4	4	HM	9000	+
125	44	40	3 x R5	4	HSS	9000	+
125	44	40	3 x R5	4	HM	9000	+
125	36	40	2 x R6	4	HSS	9000	+
125	36	40	2 x R6	4	HM	9000	+
125	44	40	2 x R8	4	HSS	9000	+
125	44	40	2 x R8	4	HM	9000	+

P-116 4.0

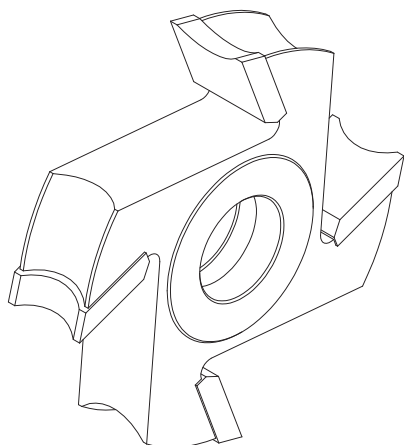

Brazed profiled cutter, type **P-116** with four cutting teeth, designed for professional machining of wood and wood-based materials such as chipboard, MDF and others. The cutter is used for edge rounding with radius R according to client's request.

Type of work: edge rounding.

Material:

- HSS solid softwood
- HM solid hardwood, glued wood, chipboard, MDF

3

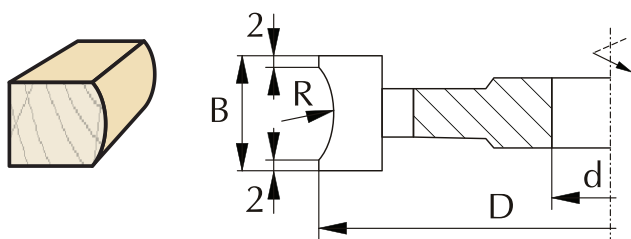

D n _{max} d _{max}	100 9000 30		125 9000 40		140 6000 50		
	B mm	HSS	HM	HSS	HM	HSS	HM
20		+	+	+	+	+	+
30		+	+	+	+	+	+
40		+	+	+	+	+	+
50		+	+	+	+	+	+

Profile cutter diameter (D) may change - more information on page 3.15

Braided profile cutter, type **FDR-01** with four cutting teeth, designed for professional machining of wood. The cutter is used for fluting flat surfaces.

Type of work: profiling flat surfaces.

Material: solid wood.

FDR-01 4.0

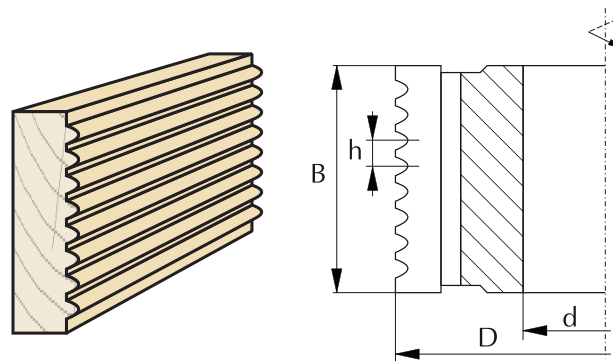
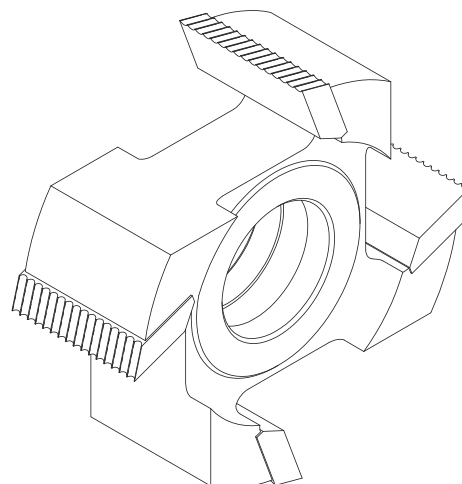

3



D	n _{max}	d _{max}	z	B mm	h mm	100	125	140
						9000	9000	6000
						30	40	50
						4	4	4
						HSS	HSS	HSS
				65	3	+	+	+
				65	4	+	+	+
				85	3	+	+	+
				85	4	+	+	+
				105	3	+	+	+
				105	4	+	+	+

FDKO

Brazed straight cutter, type **FDKO**, designed for profiling wooden dowel pins with round profile of various dimensions.

Type of work: longitudinal.

Material: solid soft wood.

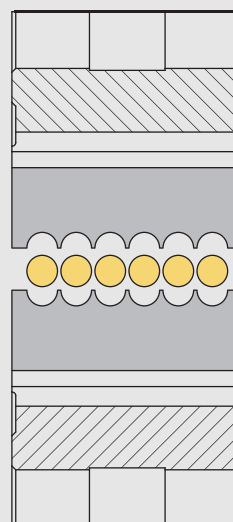
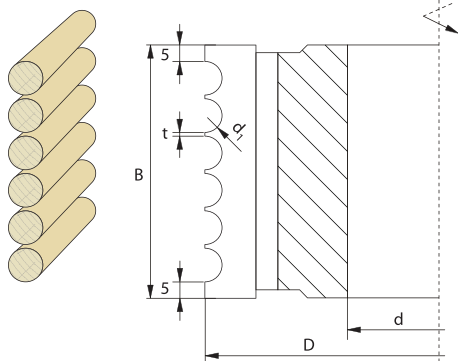
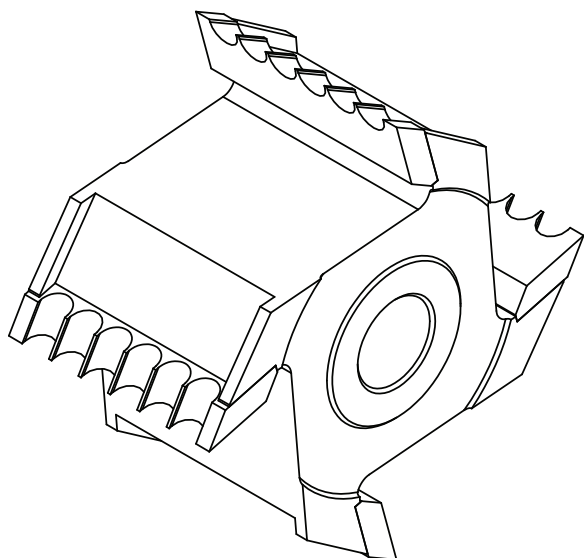

D mm	125	125	125	125	125	125	125	125	140	140	140	140
n_{max}	9000	9000	9000	9000	9000	9000	9000	9000	6000	6000	6000	6000
d_1 mm	3	4	5	6	8	10	12	15	18	20	25	30
t_{min} mm	1	1	1	1	1	1	1,5	1,5	2	2	2	2
Max. pins number	12	12	10	10	8	8	6	6	5	4	3	3
Profile FDKO	+	+	+	+	+	+	+	+	+	+	+	+

When ordering FDKO cutters, please give tool dimensions (D, d, z) as well as type of material, number of pins, their diameter (d_1) and distance between pins (t).

FDKR

Brazed straight cutter, type FDKR, designed for profiling wooden dowel pins with serrated profile of various dimensions.

Type of work: longitudinal.

Material: solid soft wood.

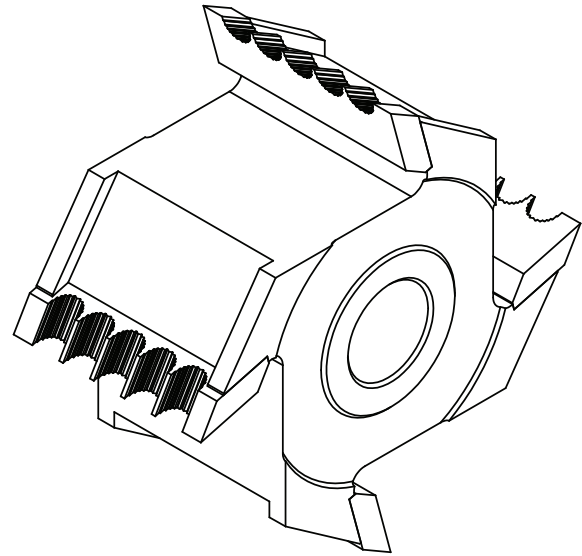

3

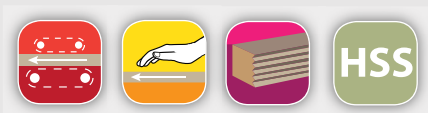
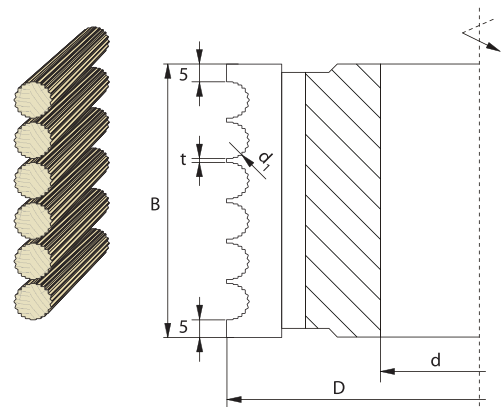
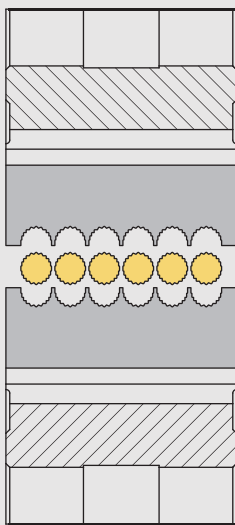

D mm	125	125	125	125	125	140	140	140	140
n _{max}	9000	9000	9000	9000	9000	6000	6000	6000	6000
d ₁ mm	6	8	10	12	15	18	20	25	30
t _{min} mm	1	1	1	1,5	1,5	1,5	2	2	2
Max. pins number	10	8	8	6	6	5	4	3	3
Profile FDKR	+	+	+	+	+	+	+	+	+

When ordering FDKR cutters, please give tool dimensions (D, d, z) as well as type of material, number of pins, their diameter (d1) and distance between pins (t).

Diameters

Outer diameter of angle cutter (D) is tightly connected with and depends on bore diameter (d), cutter width (B) and angle (α).

In order to determine the minimum diameter of angle cutter, the following diagram should be used.

Diagram is valid for bore $d=30$ mm

For bore 40 mm: $D + 10$ mm

For bore 50 mm: $D + 20$ mm

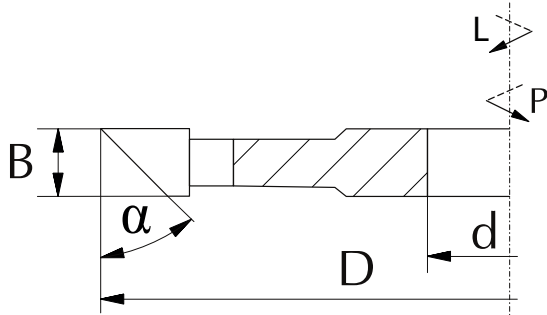

3

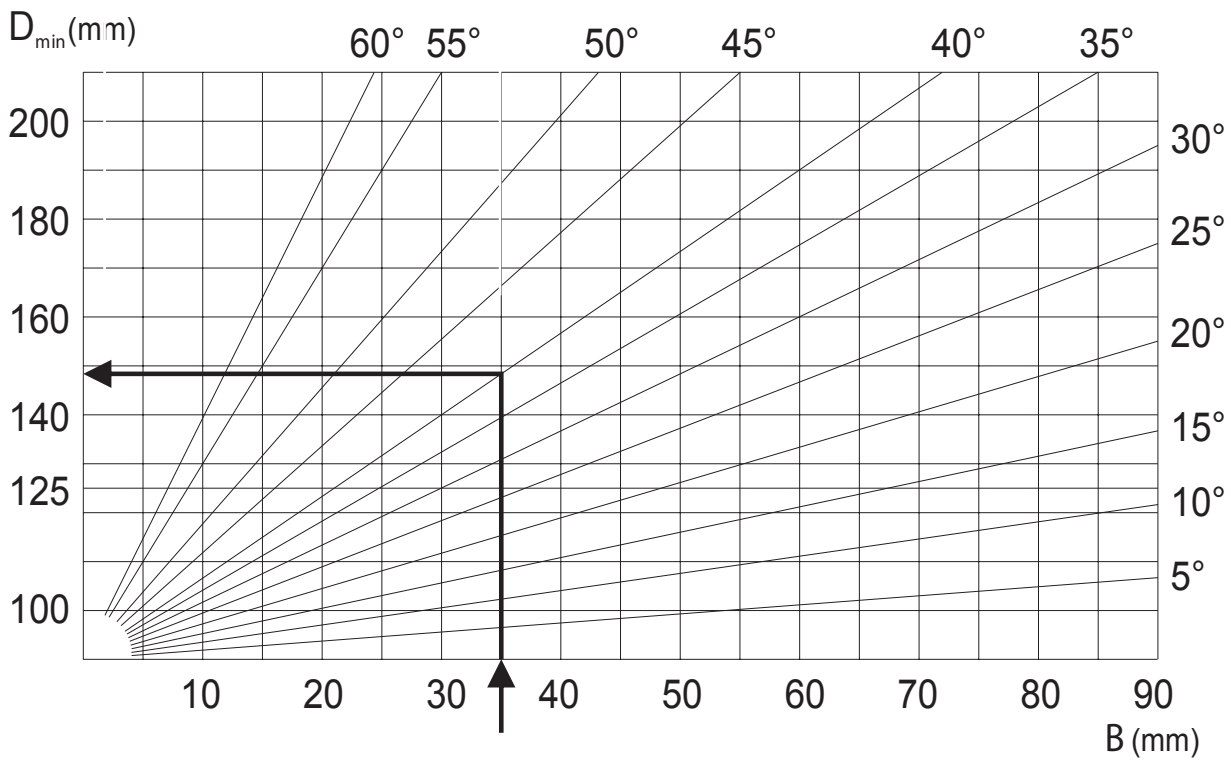

Example:

B = 35 mm

$\alpha = 40^\circ$

d = 30 mm

according to diagram $D_{min} = 148$ mm

Round for nearest typical bigger than D_{min} D = 160 mm

Brazed profile cutter, type **1201** with four cutting teeth and shear angle, designed for professional machining of wood and wood-based materials such as chipboard, MDF and others. The cutter is used for edge beveling of the machined elements.

Type of work: edge beveling at 45° angle.

Material:

- HSS** solid softwood
- HM** solid hardwood, glued wood, chipboard, MDF

1201 4.1 ∇ 45°

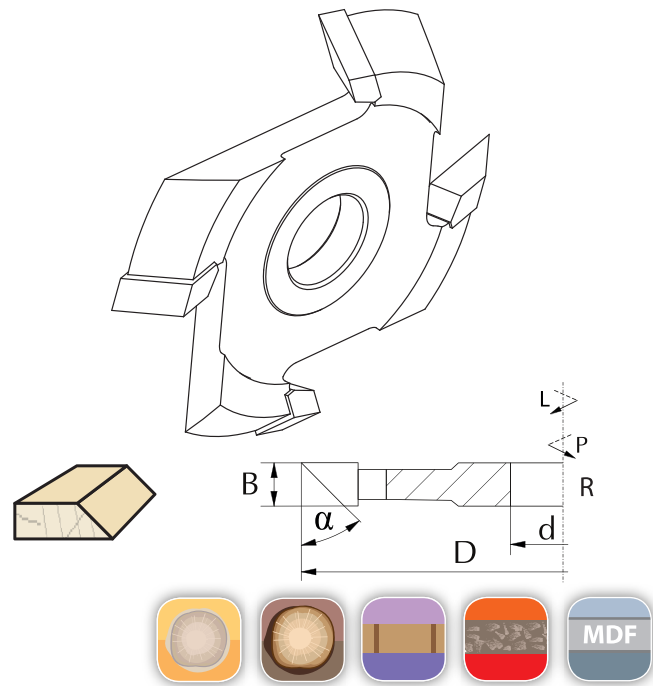

D n _{max} d _{max}	100 9000 25		125 9000 35		160 6000 40	
	HSS	HM	HSS	HM	HSS	HM
B mm						
10	+	+	+	+	+	+
15	+	+	+	+	+	+
20			+	+	+	+
25			+	+	+	+
30					+	+

Catalogue number	Type	D mm	B mm	d mm	z				
1201S125P0001	1201	125	25	30	4	HSS	45°	R	•
1201S125L0001	1201	125	25	30	4	HSS	45°	L	•
1201W125P0002	1201	125	25	30	4	HM	45°	R	•
1201W125L0004	1201	125	25	30	4	HM	45°	L	•

Type of work: edge beveling at 30° or 15° angle

1201 4.1 ∇ 30° or ∇ 15° R or L

D n _{max} d _{max} α	100 9000 25 15°		100 9000 25 30°		125 9000 30 15°		125 9000 30 30°		160 6000 40 15°		160 6000 40 30°	
	HSS	HM	HSS	HM	HSS	HM	HSS	HM	HSS	HM	HSS	HM
B mm												
10	+	+	+	+	+	+	+	+	+	+	+	+
15	+	+	+	+	+	+	+	+	+	+	+	+
20	+	+	+	+	+	+	+	+	+	+	+	+
25					+	+	+	+	+	+	+	+

Angle cutter diameter may change - more information on page 3.24.

3110 6.0

Brazed straight cutter, type **3110** with six cutting teeth, designed for professional machining of wood and wood-based materials such as chipboard, MDF and others. The cutter is used for removing veneer overplus and machining flat surfaces.

Type of work: removing veneer overplus.

Material: solid hardwood, glued wood, chipboard, MDF.

3

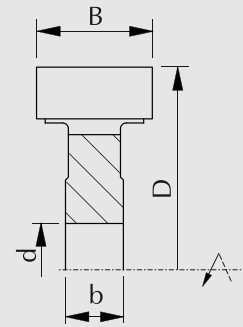
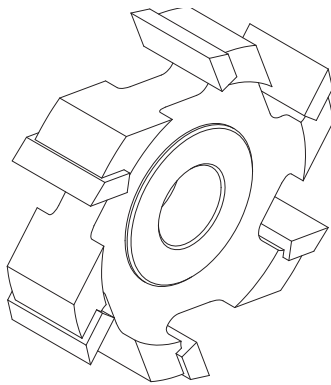
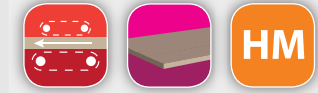

Catalogue number	Type	D mm	B mm	b mm	d mm	z		
3110W070-0019	3110	70	20	10	16	6	HM	+

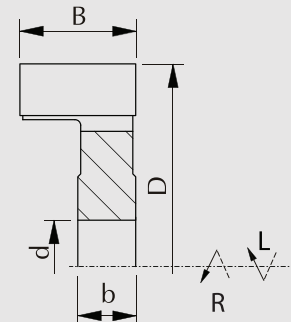
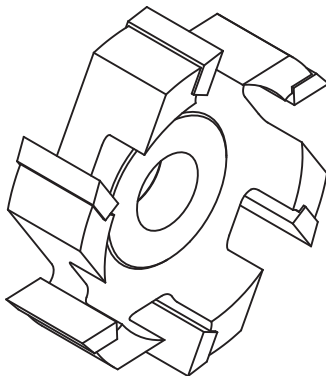

Catalogue number	Type	D mm	B mm	b mm	d mm	z			
3110W070P0001	3110	70	20	10	16	6	HM	R	+
3110W070L0001	3110	70	20	10	16	6	HM	L	+

3110 HSK25

Brazed straight cutter, type **3110 HSK25** with four cutting teeth and shear angle, designed for professional machining of wood and wood-based materials such as chipboard, MDF and others. The cutter is used for removing veneer overplus and machining flat surfaces.

HSK25 clamping guarantees precise tool positioning. Shear angle enabling optimal chip flow allows for high quality of the machined surface.

Type of work: removing veneer overplus and machining flat surfaces.

Material: solid hardwood, glued wood, chipboard, MDF.

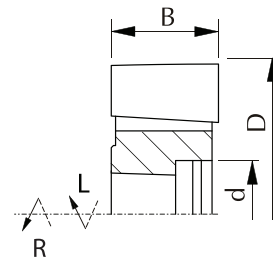
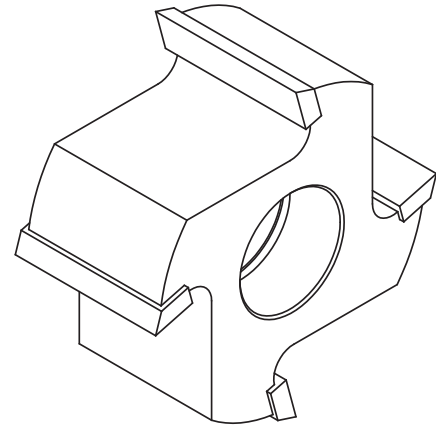

3



Catalogue number	Type	D mm	B mm	d mm	z		n_{max}		
F52-0048WP	3110	70	25	HSK25	4	HM	18000	R	+
F52-0048WL	3110	70	25	HSK25	4	HM	18000	L	+
F52-0032WP	3110	70	35	HSK25	4	HM	18000	R	+
F52-0032WL	3110	70	35	HSK25	4	HM	18000	L	+

F56-A 6.1

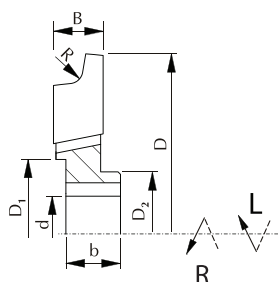
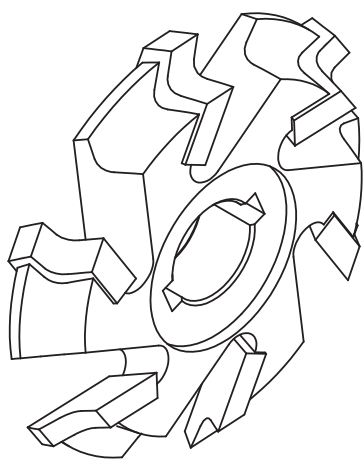

Brazed profile cutter, type **F56-A** with six cutting teeth and shear angle, designed for professional machining of wood and wood-based materials such as chipboard, MDF and others. The cutter is used for edge rounding with radius according to client's request. Shear angle enabling optimal chip flow allows for high quality of the machined surface.

Type of work: edge rounding with radius R.

Material: solid hardwood, glued wood, chipboard, MDF.



Catalogue number	Type	D mm	D ₁ mm	D ₂ mm	B mm	b mm	d mm	R mm	z	n _{max}	↕	
F56-0055WP	F56	73	30	25	10	11	16	3	6	18000	R	+
F56-0055WL	F56	73	30	25	10	11	16	3	6	18000	L	+

F56-B 6.0

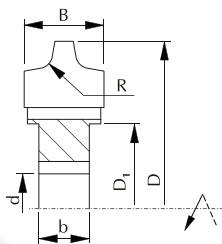
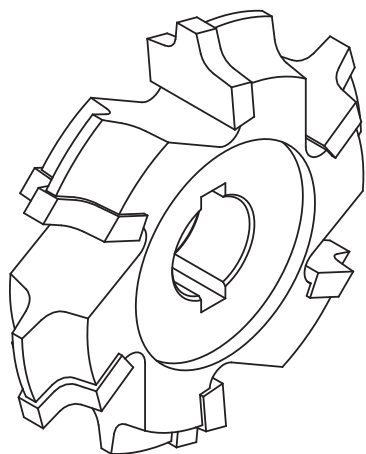

Brazed profile cutter, type **F56-B** with six cutting teeth and shear angle, designed for professional machining of wood and wood-based materials such as chipboard, MDF and others. The cutter is used for two-sided edge rounding with radius according to client's request.

Type of work: edge rounding with radius R.

Material: solid hardwood, glued wood, chipboard, MDF.



Catalogue number	Type	D mm	D ₁ mm	D ₂ mm	B mm	b mm	d mm	R mm	z	n _{max}	
F56-0056W	F56	73	37	17,4	10	11	16	3	6	18000	+

Brazed profile cutter, type **FL-01** with four or six cutting teeth and alternative shear angle, designed for professional machining of wood and glued wood. The cutter is used for repairing resin pockets. Alternative shear angle enabling optimal chip flow allows for high quality of the machined surface.

Type of work: repairing resin pockets.

Material:

- HSS solid softwood
- HM solid hardwood, glued wood



FL-01

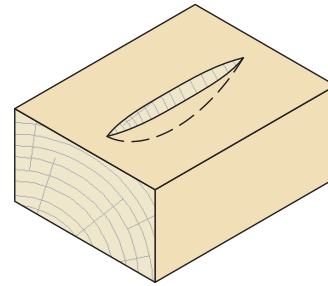

FL-01-A 4.2

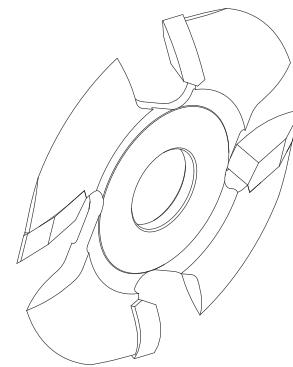
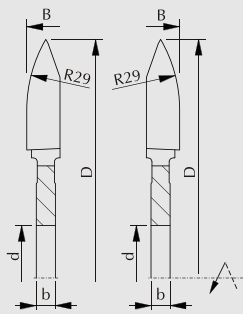

Catalogue number	Type	D mm	B mm	b mm	d mm	z		
FL01S100-001	FL-01-A	100	8	4	22	4	HSS	+
FL01W100-001	FL-01-A	100	8	4	22	4	HM	+

FL-01-B 6.2

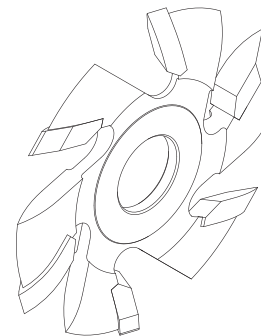
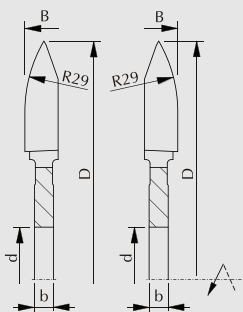

Catalogue number	Type	D mm	B mm	b mm	d mm	z		
FL01S100-006	FL-01-B	100	8	4	22	6	HSS	+
FL01W100-006	FL-01-B	100	8	4	22	6	HM	+

PATE 01

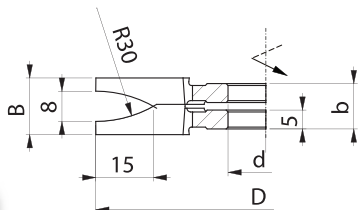
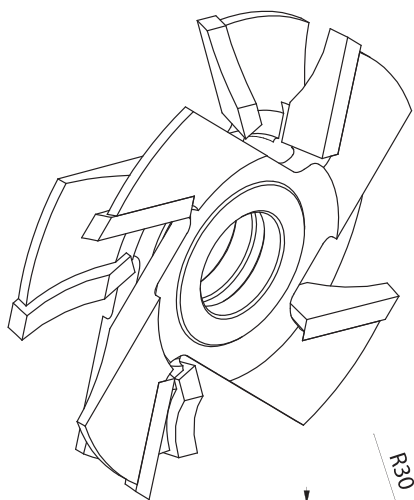

Set of brazed profile cutters type **PATE 01** with four cutting teeth and shear angle, designed for professional machining of wood and glued wood. The cutter is used for repairing resin pockets. Special construction of the set and shear angle allow for high quality of the machined surface. Special geometry enables working together with profile cutters type FL-01.

Type of work: machining resin pockets fillings

Material:

- HSS solid softwood
- HM solid hardwood, glued wood

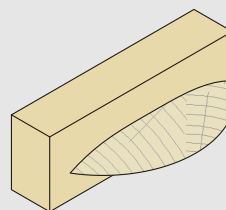

Catalogue number	Type	D mm	B mm	b mm	d mm	z	n _{max}
PATE-01.00	PATE 01	90	15	12	16	4	HM 12000 +

PATE 09

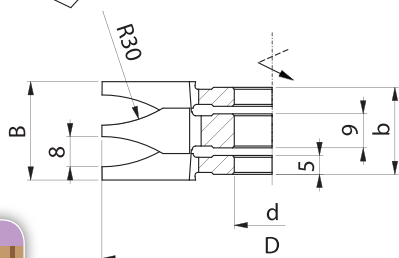
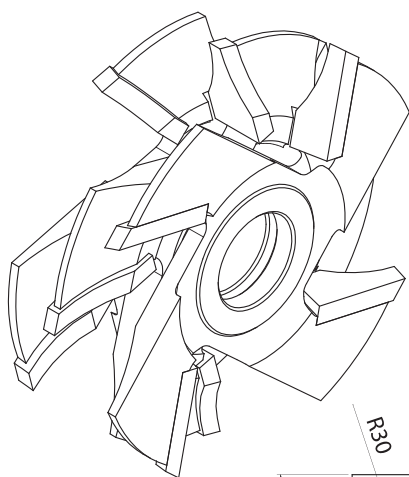

Set of brazed profile cutters type **PATE 09** with four cutting teeth and shear angle, designed for professional machining of wood and glued wood. The cutter is used for repairing resin pockets. Special construction of the set and shear angle allow for high quality of the machined surface. Special geometry enables working together with profile cutters type FL-01. The set machines two elements with the same dimensions at the same time.

Type of work: machining resin pockets fillings

Material:

- HSS solid softwood
- HM solid hardwood, glued wood

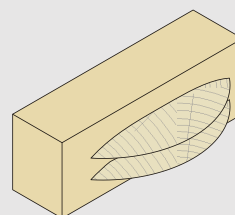

Catalogue number	Type	D mm	B mm	b mm	d mm	z	n _{max}
PATE-09.00	PATE 09	90	15	12	16	4	HM 12000 +

Set of brazed profile cutters type **PATE 10** with four cutting teeth and shear angle, designed for professional machining of wood and glued wood. The cutter is used for repairing resin pockets. Special construction of the set and shear angle allow for high quality of the machined surface. Special geometry enables working together with profile cutters type FL-01. The set machines several elements with various depth at the same time.

Type of work: machining resin pockets fillings.

Material:

HSS solid softwood

HM solid hardwood, glued wood

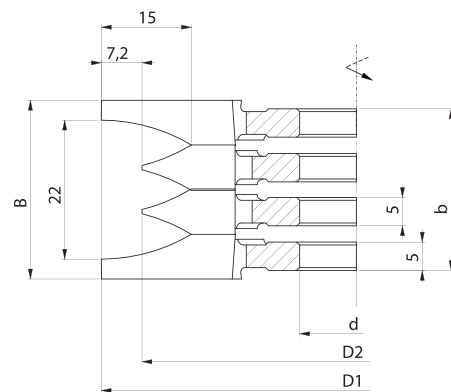
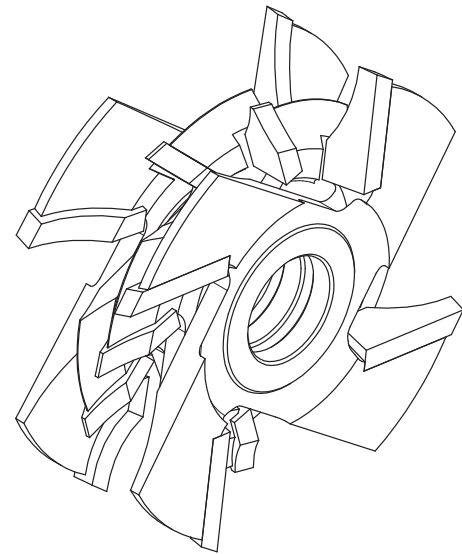
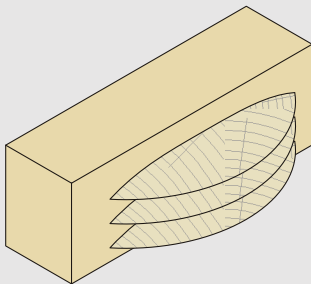

3



Catalogue number	Type	D _{mm}	D ₂ mm	B mm	b mm	d mm	z	n _{max}	
PATE-10.00	PATE 10	90	75,6	29	26	16	4	HM	12000 +

Sets of cutters

Brazed profile cutter sets designed for professional machining of solid wood, for tongue-groove joints (wainscots, parquet, floor board, casing board) and wood-based materials such as chipboard, MDF etc., for furniture door machining, edge rounding and others.

Sets for making tongue-groove joints are designed for working on 2 spindle machines with feed speed up to 30 m/min. The set includes spacer rings allowing for proper adjustment of tongue-groove width. Optionally, we offer the sets with shear angle mounted on hydro sleeves designed for professional, very precise machining of solid wood and other wood-based materials with feed speed up to 200 m/min.

On request, we suggest, design and manufacture the proper set of cutters for the required type of work, material and machine as well as parameters and conditions of work.

Cutting diagrams

As standard, we offer the sets according to diagram 1. On client's request we offer also the sets according to diagram 2.

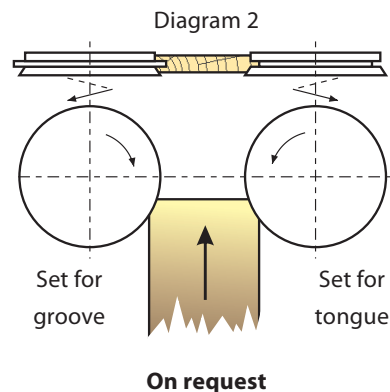
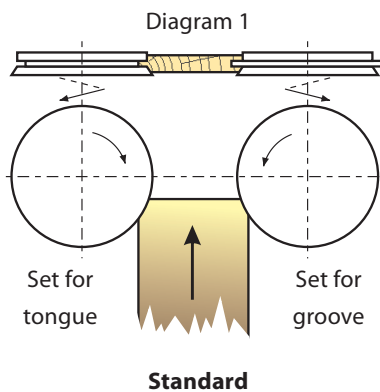

Sets of cutters coding system

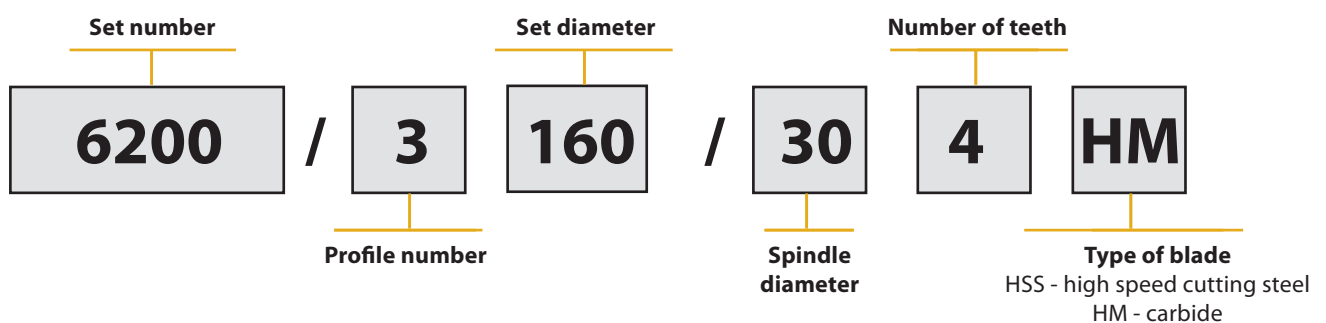

6200

3

Set of brazed profile cutters type **6200** with four cutting teeth, designed for professional machining of solid wood. The set is used for making tongue and groove in wainscots production. Width is regulated with spacer rings included in the set. The set can work on 2-spindle machines.

Type of work: longitudinal profiling of tongue and groove.

Material:

- HSS solid softwood
- HM solid hardwood

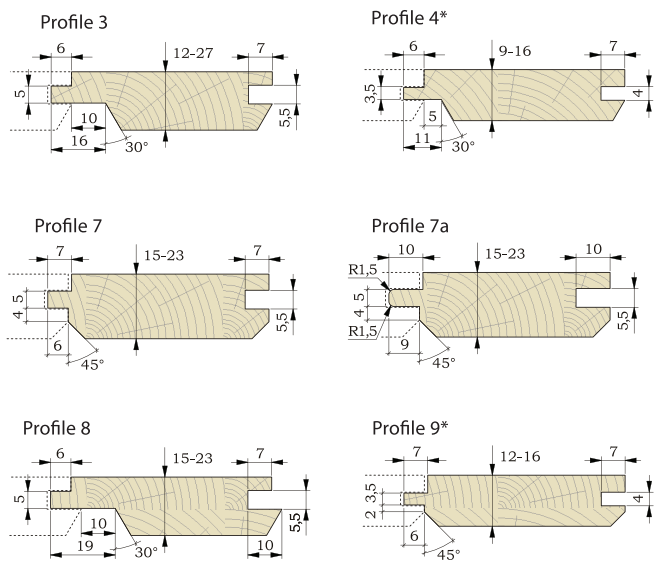
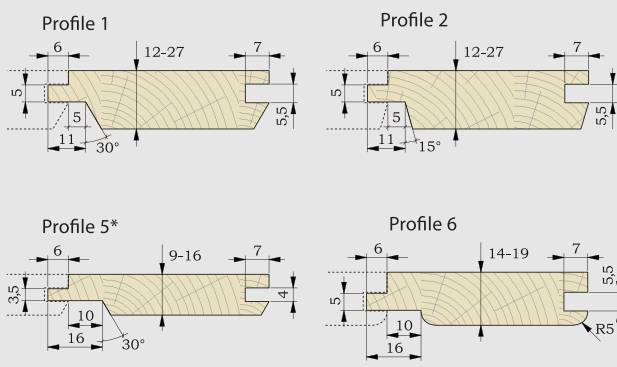
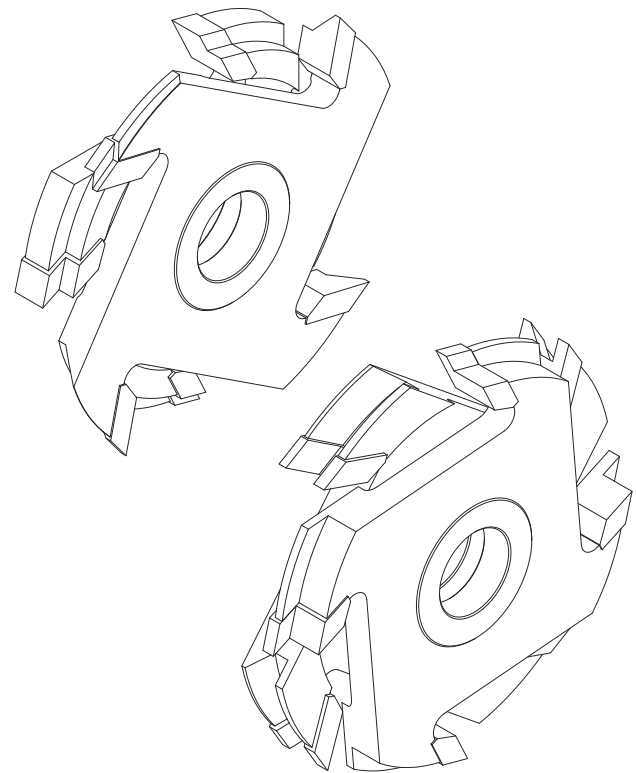
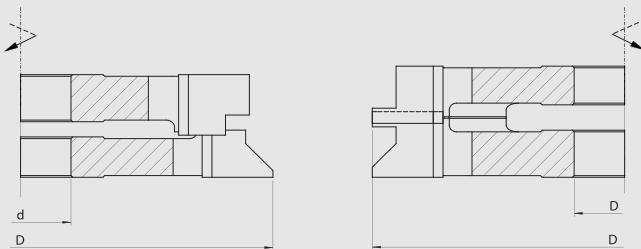

D mm	d _{max} mm	n _{max}	
125	30	9000	+
140	40	6000	+
160	40	6000	+



Catalogue number	Type	Profile	D mm	d mm	z	n _{max}	
B0700S125A0002	6200	7	125	30	4	9000	•
B0700W125A0002	6200	7	125	30	4	9000	+
B0700S140A0004	6200	7	140	40	4	6000	•
B0700W140A0003	6200	7	140	40	4	6000	+



* Profiles 4, 5 and 9 are made as HM in set with scoring saw blade for groove.

6200-2

Set of brazed profile cutters type **6200-2** with four cutting teeth, designed for professional machining of solid wood. The set is used for making tongue and groove in profile wainscots production. Width is regulated with spacer rings included in the set. The set can work on 4-spindle machines.

Type of work: longitudinal profiling of tongue and groove.

Material:

-  solid softwood
-  solid hardwood

3

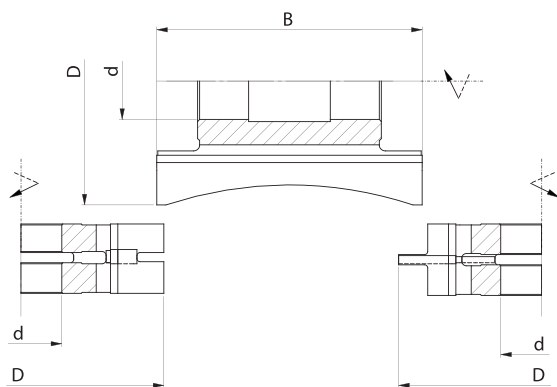
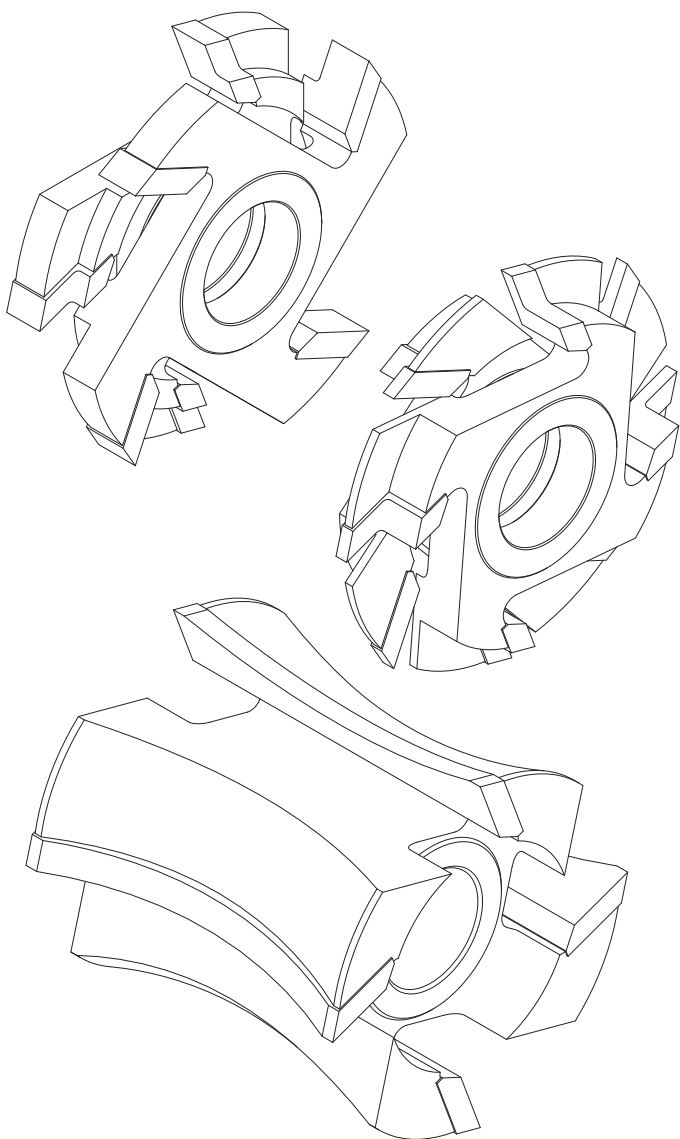

D mm	d _{max} mm	n _{max}	
140	40	6000	+
160	40	6000	+

Profile 14

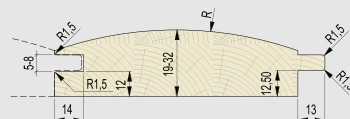

Profile 15

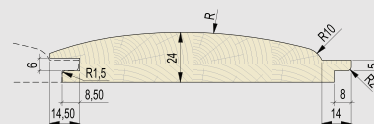

Profile 16

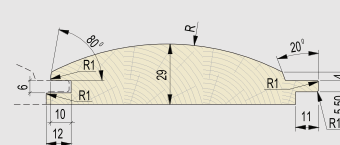



Catalogue number	Type	Profile	D mm	B mm	R mm	d mm	z		n _{max}	
F01-1283-00S	6200-2	16	140	121	120,9	40	4	HSS	6000	+
F02-0946-00S	6200-2	14	140	130	176	40	4	HSS	6000	+
F04-0800-00BSP	6200-2	15	140	153	237	40	4	HSS	6000	+

6200

Set of brazed profile cutters type **6200** with four cutting teeth, designed for professional machining of solid wood. The set is used for making tongue and groove in floor board production. Width is regulated with spacer rings included in the set. The set can work on 2-spindle machines.

Type of work: longitudinal profiling of tongue and groove.

Material:

-  solid softwood
-  solid hardwood

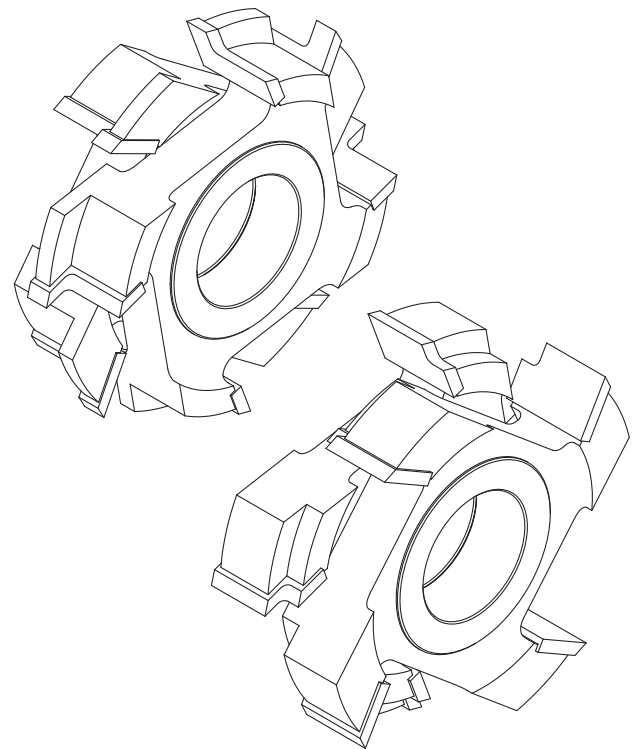
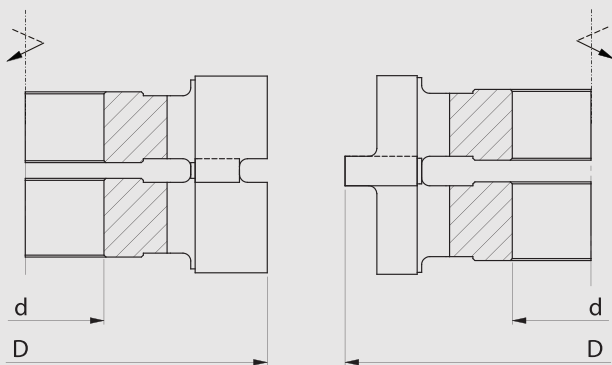

D mm	125		140		160	
d mm	30		40		40	
n _{max}	9000		6000		6000	
B mm	HSS	HM	HSS	HM	HSS	HM
15-27	+	+	+	+	+	+
28-50	+	+	+	+	+	+

Profile 10

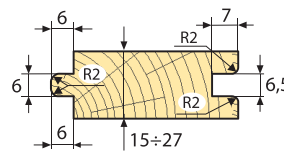

Profile 11

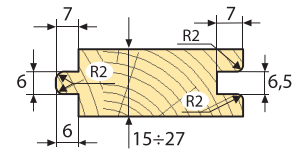

Profile 12

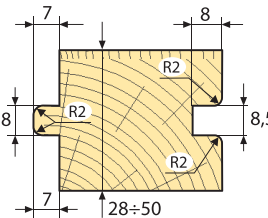

Profile 13

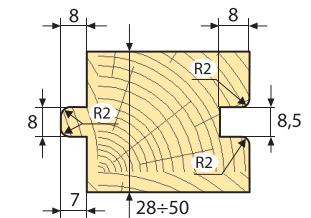



Catalogue number	Type	Profile	D mm	d mm	z	n _{max}	
D1100S125A0003	6200	11	125	30	4	HSS	9000 +
D1100W125A0002	6200	11	125	30	4	HM	9000 +
D1300S140A0003	6200	13	140	30	4	HSS	6000 +
D1300S140A0002	6200	13	140	40	4	HSS	6000 •
D1300W140A0002	6200	13	140	30	4	HM	6000 +
D1300W140A0003	6200	13	140	35	4	HM	6000 +
D1100S140A0001	6200	11	140	40	4	HSS	6000 •
D1100W140A0002	6200	11	140	35	4	HM	6000 +
D1100W140A0001	6200	11	140	40	4	HM	6000 +
D1300S160A0001	6200	13	160	40	4	HSS	6000 •
D1300W160A0001	6200	13	160	40	4	HM	6000 +

6200 Side cutters

Brazed profile cutters type **6200** with four cutting teeth, designed for professional machining of solid wood. Side cutter is used for edge beveling of the machined elements. Special geometry allows for working together with sets for floor board.

Type of work: edge beveling of floor board.

Material:

-  solid softwood
-  solid hardwood

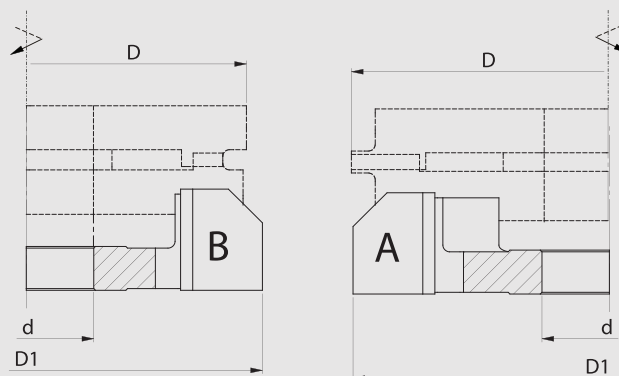
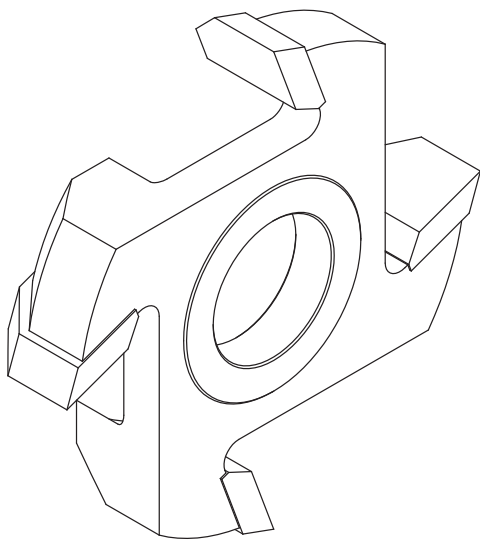

Profile 10

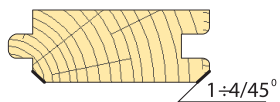

Profile 11

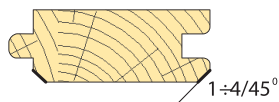

Profile 12

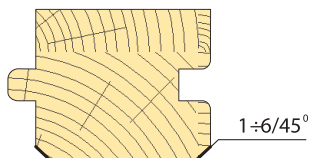

Profile 13

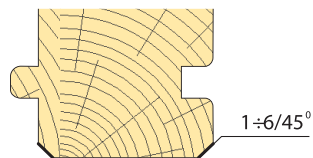

D mm	140	140	160	160		
D ₁ mm	140	152	160	174		
d ₁ mm	40	40	40	40		
n _{max}	6000	6000	6000	6000		
	HSS	HM	HSS	HM	HSS	HM
A	+	+			+	+
B			+	+		



Catalogue number	Type	Profile	D1 mm	d mm	z		n _{max}		
F04-1787SL	6200A	10/11	140	40	4	HSS	6000	L	+
F04-1786SP	6200B	10/11	152	40	4	HSS	6000	R	+
F04-1787CWL	6200A	10/11	140	40	4	HM	6000	L	+
F04-1786CWP	6200B	10/11	152	40	4	HM	6000	R	+
F04-1787ASL	6200A	12/13	160	40	4	HSS	6000	L	+
F04-1786ASP	6200B	12/13	174	40	4	HSS	6000	R	+
F04-1787AWL	6200A	12/13	160	40	4	HM	6000	L	+
F04-1787AWP	6200B	12/13	174	40	4	HM	6000	R	+

7311

Set of brazed profile cutters type **7311** with four cutting teeth, designed for professional machining of solid wood. The set is used for making tongue and groove in parquet board production. Width is regulated with spacer rings included in the set. The set can work on 2-spindle machines.

Type of work: longitudinal profiling of tongue and groove.

Material:

- HSS solid softwood
- HM hardwood, glued wood, MDF

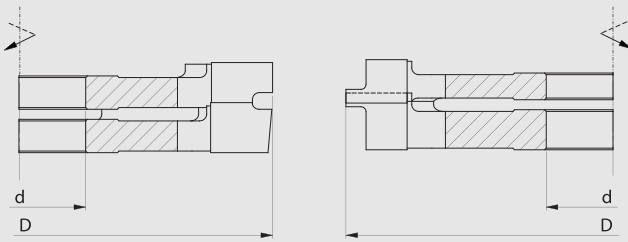

Profile P1

Profile P2

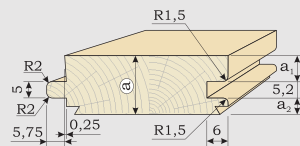
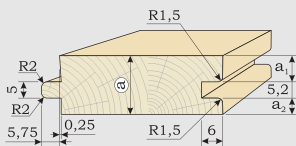

D mm d mm n _{max}	140 40 6000		160 50 6000	
	HSS	HM	HSS	HM
Profile P1	+	+	+	+
Profile P2	+	+	+	+

Profile	a	a1	a2
P1 i P2	16	7	3,9
P1 i P2	19	8,5	5,3
P1 i P2	22	10	6,8

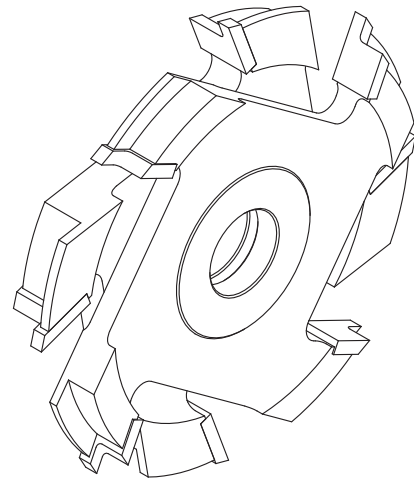
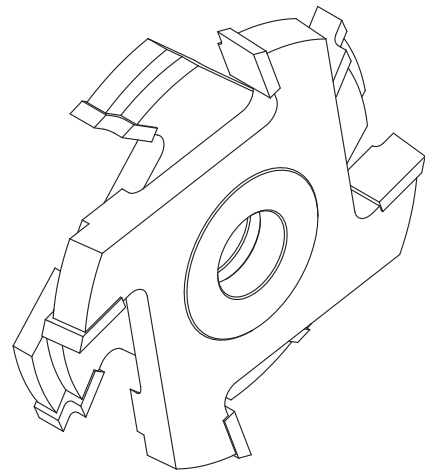

Catalogue number	Type	Profile	D mm	d mm	z	n _{max}	
P1-00S140A001	7311	P1	140	40	4	HSS	6000 +
P1-00W140A001	7311	P1	140	40	4	HM	6000 +
P1-00S160A001	7311	P1	160	50	4	HSS	6000 +
P1-00W160A001	7311	P1	160	30	4	HM	6000 +
P2-00S140A001	7311	P2	140	40	4	HSS	6000 +
P2-00W140A001	7311	P2	140	40	4	HM	6000 +
P2-00S160A001	7311	P2	160	50	4	HSS	6000 +
P2-00W160A001	7311	P2	160	30	4	HM	6000 +

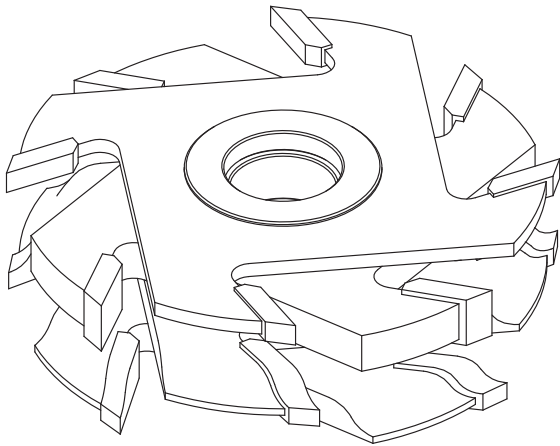

FP-03



Set of brazed profile cutters type **FP-03** with four cutting teeth, designed for professional machining of wood and wood-based materials such as chipboard, MDF and others. The set is used for making longitudinal profiling and tenoning of furniture doors. Width is regulated with spacer rings included in the set. Regulation range 22-35 mm. One set can be used for several profiles.

Type of work: longitudinal profiling of furniture doors.

Material:

-  solid softwood
-  glued wood, chipboard, MDF

3

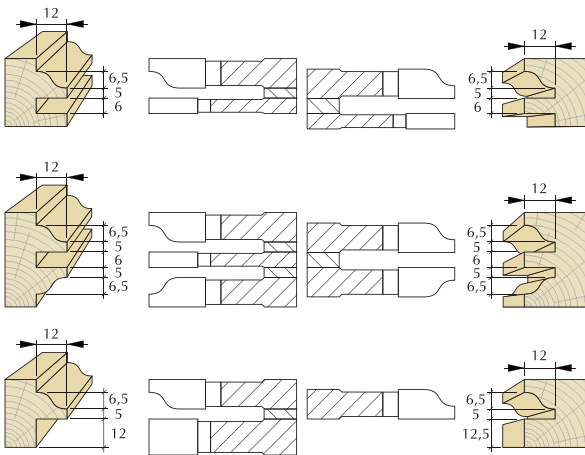
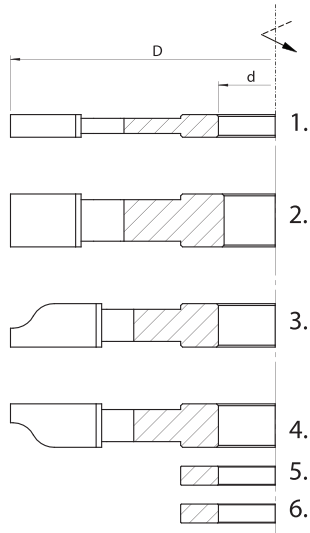

Nr	D mm	B mm	d _{max} mm	R mm	n _{max}	
1.	140	6	40		9000	+
2.	140	14	40	6	9000	+
3.	140	11,5	40	6	9000	L +
4.	140	11,5	40		9000	R +
5.	63	6	40		Distance ring 1 pc. +	
6.	63	5	40		Distance ring 2 pcs. +	

D mm	140		160	
d _{max} mm	40		40	
n _{max}	6000		6000	
	HSS	HM	HSS	HM
	+	+	+	+





Catalogue number	Type	D mm	d mm	z		n _{max}
FP0300S140-0006	FP-03	140	40	4	HSS	6000 +
FP0300W140-0001	FP-03	140	40	4	HM	6000 +
FP0300W160-0001	FP-03	160	40	4	HM	6000 +

FP-05

Set of brazed profile cutters type **FP-05** with four cutting teeth, designed for professional machining of wood and wood-based materials such as chipboard, MDF and others. The set is used for edge rounding and beveling of the machined elements. Increased regulation range. Width is regulated with spacer rings included in the set.

Type of work: edge profiling, rounding, beveling.

Material:

-  solid softwood
-  glued wood, chipboard, MDF

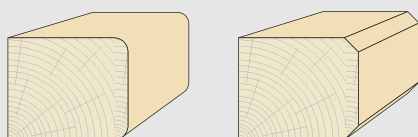

Nr	D mm	B mm	d _{max} mm	R mm / \angle	n _{max}	\curvearrowright	
1.	100	20	30	5/45°	9000	L	+
2.	86	30	30		9000		+
3.	100	20	30	5/45°	9000	R	+
1.	134	20	40	5/45°	9000	L	+
2.	120	30	40		9000		+
3.	134	20	40	5/45°	9000	R	+
4.	63	1	40				Distance ring 1 pc. +
5.	63	2	40				Distance ring 2 pcs. +
6.	63	5	40				Distance ring 2 pcs. +
7.	63	10	40				Distance ring 1 pc. +

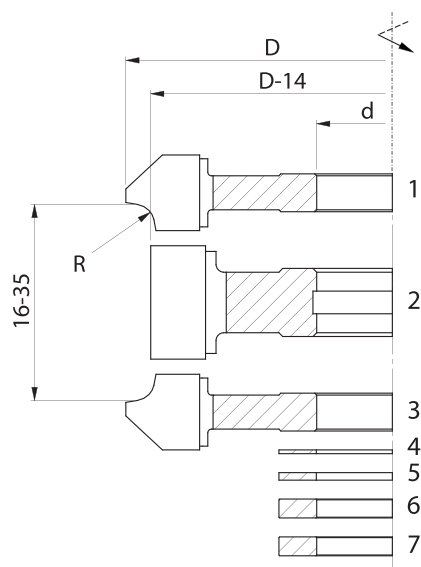
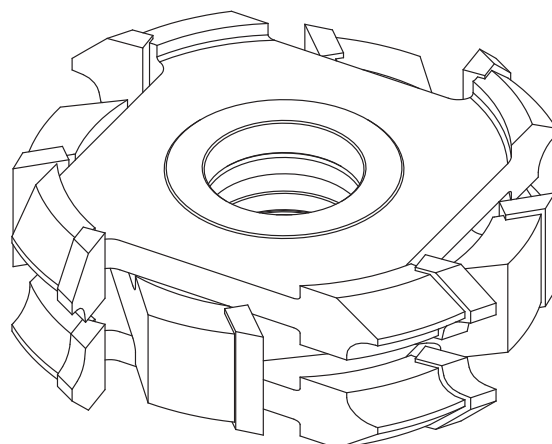

D mm d _{max} mm n _{max}	100 30 9000		134 50 9000		144 50 9000		154 50 6000		164 50 6000		174 50 6000	
	HSS	HM	HSS	HM	HSS	HM	HSS	HM	HSS	HM	HSS	HM
16-35	+	+	+	+	+	+	+	+	+	+	+	+

Catalogue number	Type		D mm	d mm	R mm / \angle	z	n _{max}	
FP0500S134-0001	FP-05	Set	134	30	5/45°	4	6000	•
FP0500W134-0002	FP-05	Set	134	30	5/45°	4	6000	+
FP0500S134-0002	FP-05	Set	134	40	5/45°	4	6000	•
FP0500W134-0001	FP-05	Set	134	40	5/45°	4	6000	•
FP0500S164-0001	FP-05	Set	164	50	5/45°	4	6000	+
FP0500W164-0001	FP-05	Set	164	50	5/45°	4	6000	+
FP0501S134P0002	FP-05.03	Cutter	134	40	5/45°	4	6000	•
FP0501S134L0002	FP-05.01	Cutter	134	40	5/45°	4	6000	•
FP0502S134-0002	FP-05.02	Cutter	120	40		4	6000	•

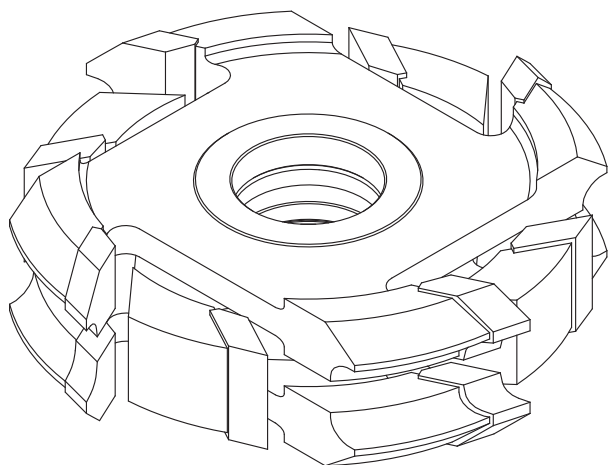

FP-06



Set of brazed profile cutters type **FP-06** with four cutting teeth, designed for professional machining of wood and wood-based materials such as chipboard, MDF and others. The set is used for edge rounding and beveling of the machined elements. Increased regulation range. Width is regulated with spacer rings included in the set.

Type of work: edge profiling, rounding, beveling.

Material:

-  solid softwood
-  glued wood, chipboard, MDF

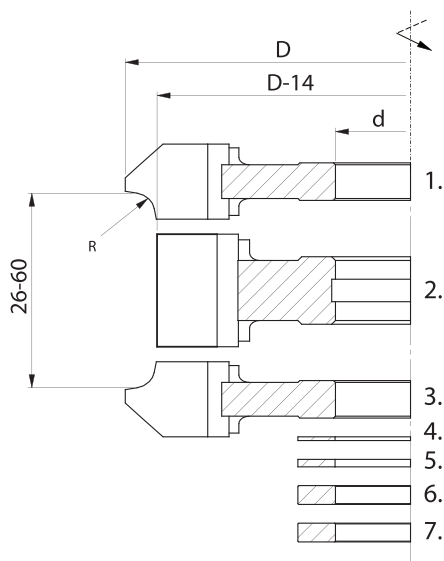
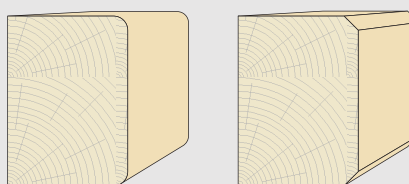

Nr	D mm	B mm	d _{max} mm	R mm / \angle	n _{max}	\curvearrowright	
1.	100	20	30	5/45°	9000	L	+
2.	86	55	30		9000		+
3.	100	20	30	5/45°	9000	R	+
1.	134	20	40	5/45°	9000	L	+
2.	120	55	40		9000		+
3.	134	20	40	5/45°	9000	R	+
4.	63	1	40		Distance ring 1 pc.		+
5.	63	2	40		Distance ring 2 pcs.		+
6.	63	5	40		Distance ring 2 pcs.		+
7.	63	10	40		Distance ring 1 pc.		+



D mm	100	134	144	154	164	174
d _{max} mm	30	50	50	50	50	50
n _{max}	9000	9000	9000	6000	6000	6000
B mm	HSS	HM	HSS	HM	HSS	HM
26-60	+	+	+	+	+	+

Catalogue number	Type		D mm	d mm	R mm / \angle	z	n _{max}
FP0600S134-0001	FP-06	Set	134	30	5/45°	4	HSS 6000 •
FP0600W134-0010	FP-06	Set	134	30	5/45°	4	HM 6000 +
FP0600S134-0002	FP-06	Set	134	40	5/45°	4	HSS 6000 •
FP0600W134-0001	FP-06	Set	134	40	5/45°	4	HM 6000 +
FP0602S134-0001	FP-06.02	Cutter	120	40	5/45°	4	HSS 6000 •

Set of brazed profile cutters type **FP-10** with four cutting teeth, designed for professional machining of wood and wood-based materials such as chipboard, MDF and others. The set is used for cutting longitudinal profiling and tenoning of one-sided furniture doors. Width is regulated with spacer rings included in the set. One set can be used for several profiles.

Type of work: Profiling furniture doors with one-sided profile.

Material:

HSS solid softwood

HM glued wood, chipboard, MDF

FP-10

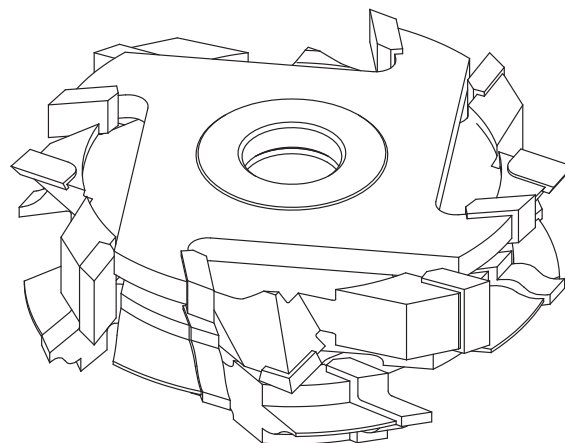

Nr	D mm	B mm	d _{max} mm	R mm	n _{max}	↕	
1.	140	20	40	6	9000	R	+
2.	140	20	40	6	9000	L	+
3.	128	10	40		9000		+
4.	128	10	40		9000		+
5.	140	5,5	40		9000		+
6.	63	3	40		Distance ring 1 pc.		+
7.	63	2	40		Distance ring 1 pc.		+

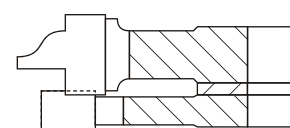
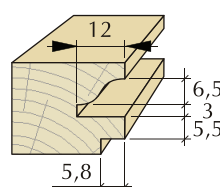
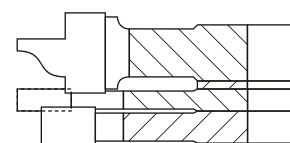
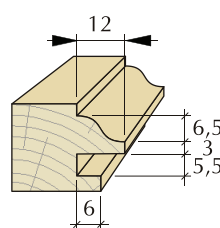
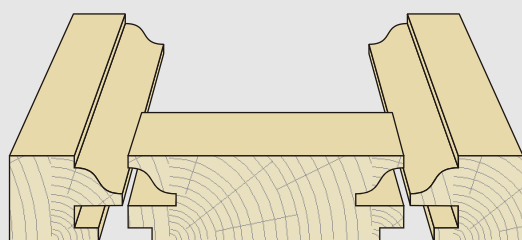
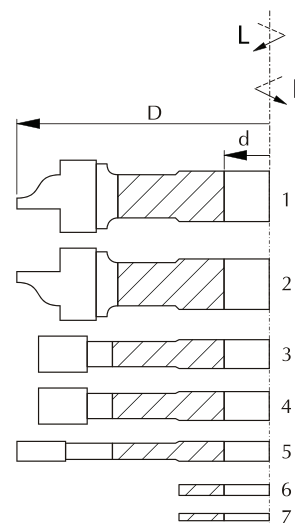

Catalogue number	Type	D mm	d mm	z	n _{max}	
FP1000S140-0001	FP-10	140	30	4	HSS	9000 •
FP1000W140-001	FP-10	140	30	4	HM	9000 +

FP-12

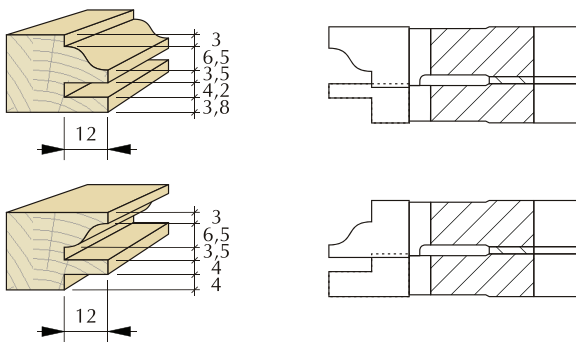
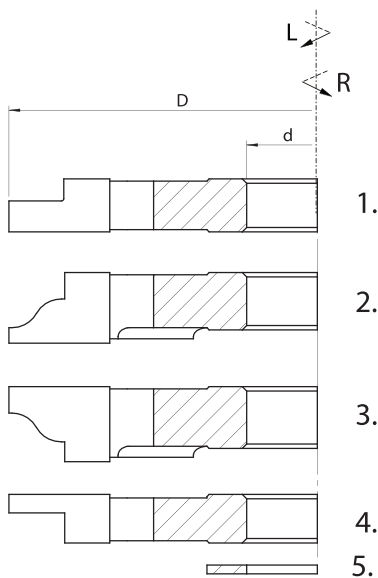
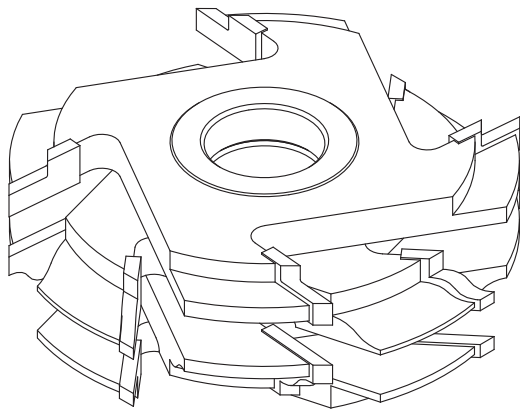

Set of brazed profile cutters type **FP-12** with four cutting teeth, designed for professional machining of wood and wood-based materials such as chipboard, MDF and others. The set is used for longitudinal profiling and tenoning of one-sided furniture doors. Width is regulated with spacer rings included in the set. One set can be used for several profiles.

Type of work: Longitudinal profiling of furniture doors with one-sided profile.

Material:

- solid softwood
- glued wood, chipboard, MDF

Nr	D mm	B mm	d _{max} mm	R mm	n _{max}	↻	
1.	140	12	40		9000	L	+
2.	140	16	40	6	9000	L	+
3.	140	17	40	6	9000	R	+
4.	140	11	40		9000	R	+
5.	63	2	40		Distance ring 2 pcs.		+

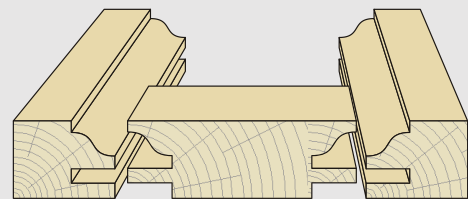

Catalogue number right	Catalogue number left	Type	D mm	d mm	z	n _{max}
FP1200S140P001	• FP1200S140L001	+ FP-12	140	30	4	HSS 9000
FP1200W140P001	• FP1200W140L001	+ FP-12	140	30	4	HM 9000
FP1200S160P001	+ FP1200S160L001	+ FP-12	160	40	4	HSS 6000

Set of brazed profile cutters type **FP-14** with three cutting teeth, designed for professional machining of wood and wood-based materials such as chipboard, MDF and others. The set is used for cutting surface in railing production.

Type of work: railing edge profiling.

Material:

- HSS solid softwood
- HM solid hardwood

FP-14

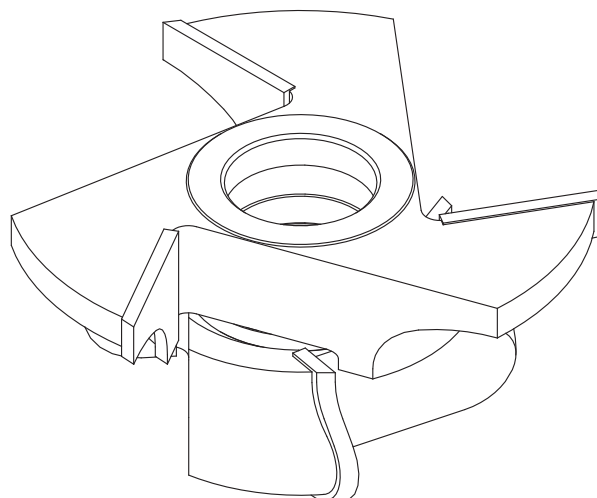

Nr	D mm	B mm	d _{max} mm	R mm	n _{max}	↕	
1.	160	35	35	50/17	9000	R	+
3.	118	41	35	14/17	9000	L	+
2.	58	6	35	Distance ring 1 pc.			+

Nr	D mm	B mm	d _{max} mm	R mm	n _{max}	↕	
1.	180	35	50	50/17	9000	R	+
3.	138	41	50	14/17	9000	L	+
2.	70	6	50	Distance ring 1 pc.			+

D mm	160	180
d _{max} mm	35	50
n _{max}	9000	9000
Profile 1	+	+

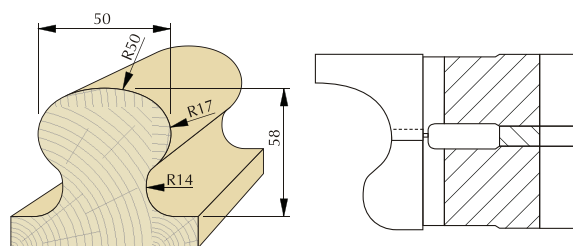
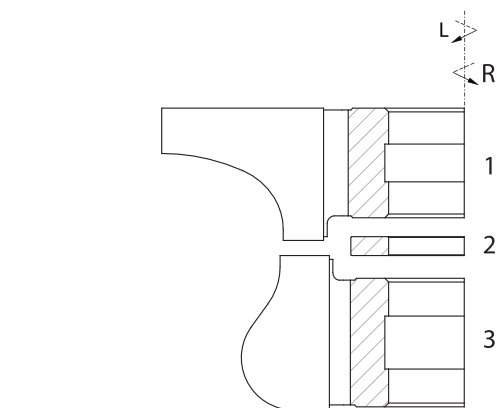

Catalogue number rigth	Catalogue number left	Type	D mm	d mm	z	n _{max}	
FP1400S160P001	• FP1400S160L001	+	FP-14	160	30	3	HSS 9000
FP1400W180P001	+ FP1400W180L001	+	FP-14	180	30	3	HM 9000
FP1400S180P001	+ FP1400S180L001	+	FP-14	180	50	3	HSS 9000

FP-15

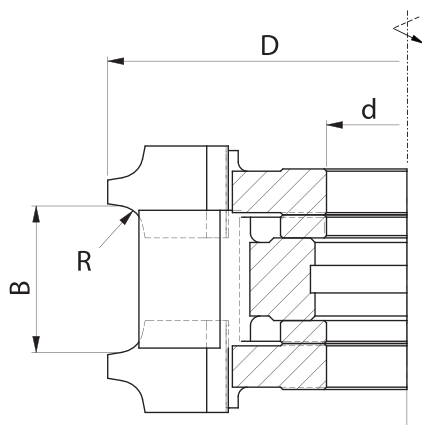
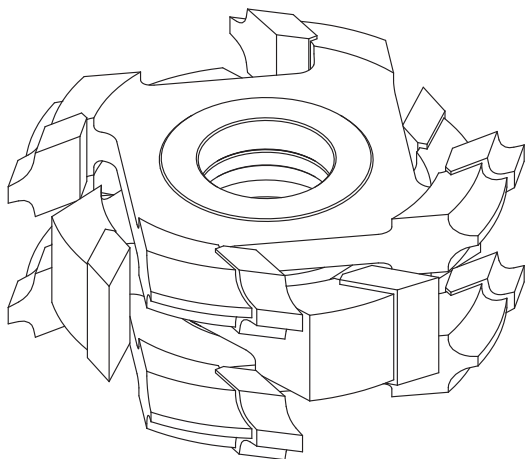

Set of brazed profile cutters type **FP-15** with four cutting teeth, designed for professional machining of wood and wood-based materials such as chipboard, MDF and others. The set is used for edge rounding of the machined elements. Width is regulated with spacer rings included in the set.

Type of work: edge profiling, corner rounding.

Material:

- HSS solid softwood
- HM glued wood, chipboard, MDF

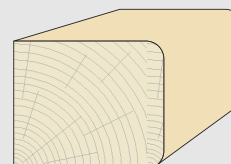

Catalogue number	Type	D mm	B mm	d mm	R mm	z		n_{max}	
FP1500S130-0001	FP-15	130	16-35	30	3	4	HSS	9000	+
FP1500W130-0001	FP-15	130	16-35	30	3	4	HM	9000	+
FP1500S132-0001	FP-15	132	16-36	35	4	4	HSS	9000	+
FP1500W132-0003	FP-15	132	16-36	40	4	4	HM	9000	+
FP1500S134-0001	FP-15	134	16-38	30	5	4	HSS	9000	+
FP1500W134-0001	FP-15	134	16-38	40	5	4	HM	9000	+
FP1500S136-0001	FP-15	136	16-40	30	6	4	HSS	9000	+
FP1500W136-0001	FP-15	136	16-40	40	6	4	HM	9000	+
FP1500S138-0001	FP-15	138	20-42	40	7	4	HSS	9000	+
FP1500W138-0001	FP-15	138	20-42	40	7	4	HM	9000	+
FP1500S140-0001	FP-15	140	20-44	30	8	4	HSS	9000	+
FP1500W140-0001	FP-15	140	20-44	40	8	4	HM	9000	+

Set of brazed profile cutters type **FP-16** with four or six cutting teeth, designed for professional machining of wood and wood-based materials such as chipboard, MDF and others. The set is used for edge beveling of the machined elements. Width is regulated with spacer rings included in the set.

Type of work: edge profiling, corner beveling.

Material:

HSS solid softwood

HM glued wood, chipboard, MDF

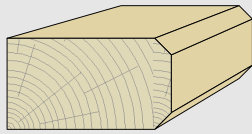

FP-16

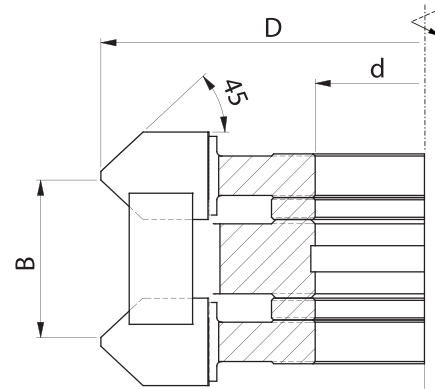
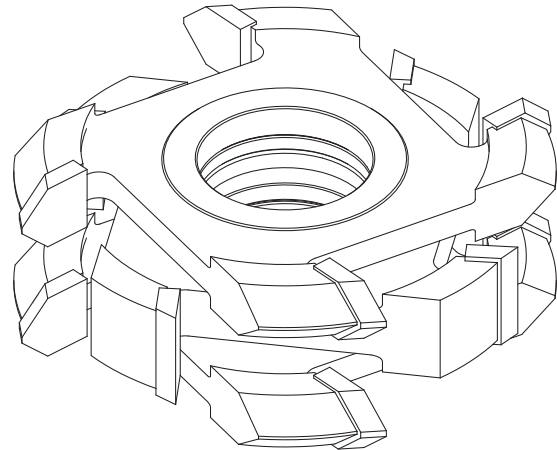

Catalogue number	Type	D mm	B mm	d mm	\angle	z		n_{max}	
FP1600S134-0015	FP-16	134	16-38	30	45°	4	HSS	9000	+
FP1600W134-0007	FP-16	134	16-38	30	45°	4	HM	9000	+
FP1600W134-0005	FP-16	134	23-60	40	45°	4	HM	9000	+
FP1600S134-0002	FP-16	134	26-60	40	45°	4	HSS	9000	+
FP1600S134-0006	FP-16	134	30-70	40	45°	4	HSS	9000	+
FP1600W134-0004	FP-16	134	30-70	40	45°	4	HM	9000	+
FP1600S154-0001	FP-16	154	16-36	40	45°	4	HSS	9000	+
FP1600W154-0001	FP-16	154	16-36	40	45°	4	HM	9000	+
FP1600W154-0002	FP-16	154	16-60	40	45°	6	HM	9000	+
FP1600S154-0002	FP-16	154	26-60	40	45°	4	HSS	9000	+
FP1600S174-0001	FP-16	174	16-36	50	45°	4	HSS	6000	+
FP1600W174-0004	FP-16	174	16-36	70	45°	6	HM	6000	+
FP1600S174-0002	FP-16	174	26-60	50	45°	4	HSS	6000	+
FP1600W194-0001	FP-16	194	16-36	40	45°	6	HM	6000	+
FP1600S194-0001	FP-16	194	16-36	40	45°	4	HSS	6000	+
FP1600S194-0003	FP-16	194	26-60	40	45°	4	HSS	6000	+

FPO-01

3

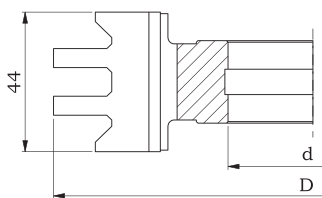
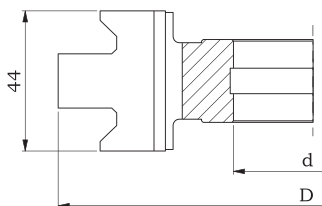
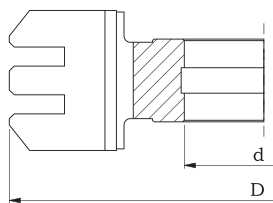
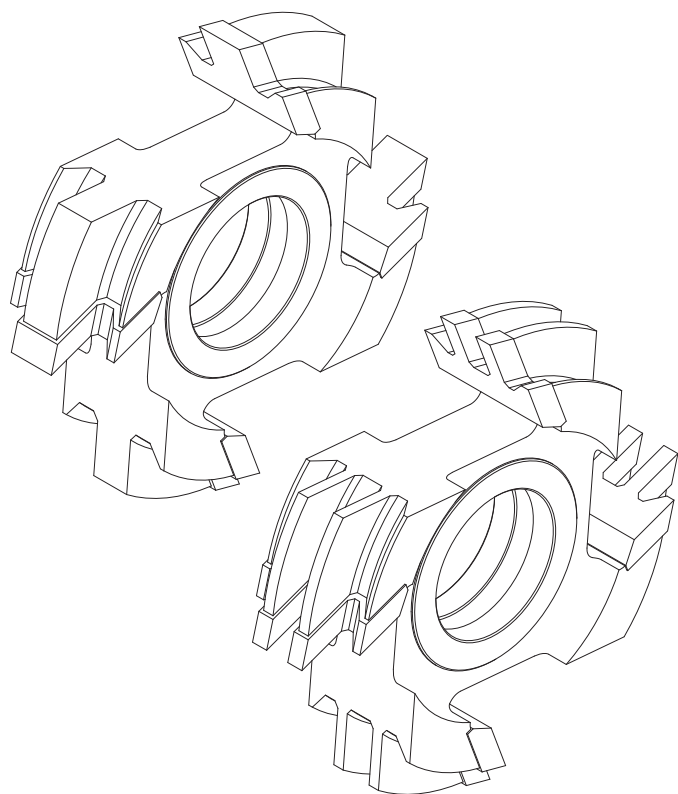

Brazed profile cutters type **FPO-01** with four cutting teeth, designed for professional machining of solid wood. The cutter is used for cutting surface in production of garden programme elements. Special geometry allows for making profiles with a single cutter.

Type of work: surface profiling.

Material:

HSS solid softwood

HM solid hardwood

Profile P1

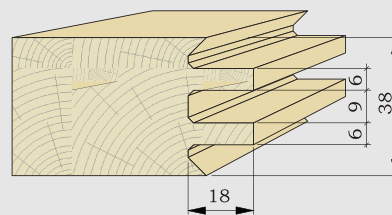

Profile P2

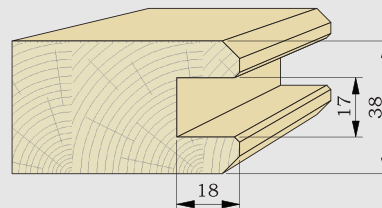

Profile P3

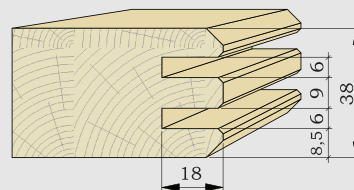

Catalogue number	Type	Profile	D mm	d mm	z		n _{max}	
F02-2234S	FPO-01	P1	160	50	4	HSS	6000	+
F02-2236S	FPO-01	P2	160	50	4	HSS	6000	+
F02-2237S	FPO-01	P3	160	50	4	HSS	6000	+

FPO-02

Set of brazed profile cutters type **FPO-02** with four cutting teeth, designed for professional machining of solid wood. The set is used for cutting surface in production of wooden walls. Width is regulated with spacer rings included in the set. Special geometry allows for making profiles with a single cutter.

Type of work: surface profiling.

Material: solid wood

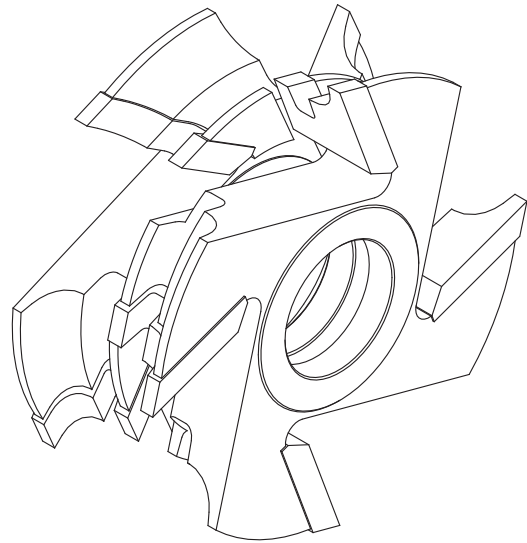

3

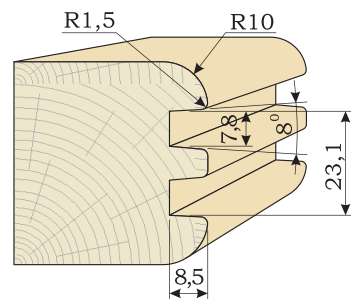
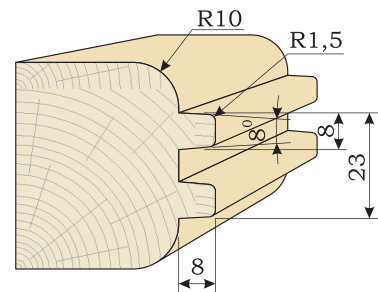
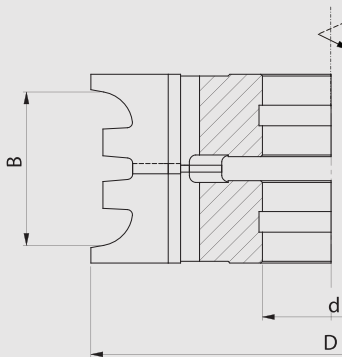
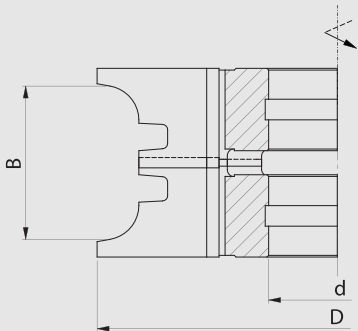

Catalogue number	Type	D mm	B mm	d mm	R	z	n _{max}	
F04-0814-005	FPO-02	140	45	40	10	4	HSS	9000 +

FPO-03

3

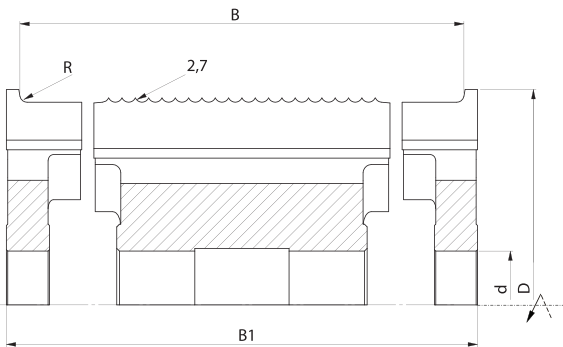
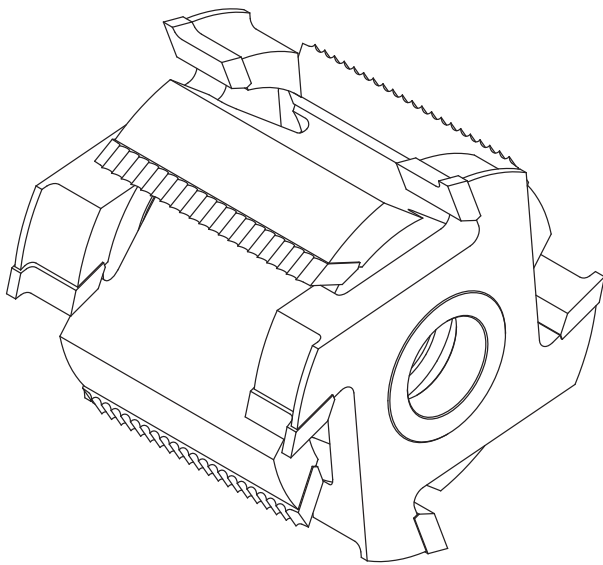

Set of brazed profile cutters type **FPO-03** with four cutting teeth, designed for professional machining of solid wood. The set is used for cutting terrace floor surface. Width is regulated with spacer rings included in the set.

Type of work: terrace floor surface profiling.

Material: solid wood

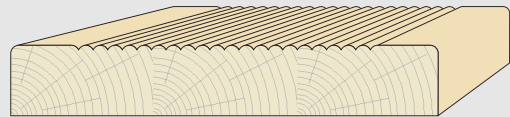

D mm	160	180
d _{max} mm	40	50
n _{max}	6000	6000
B		
120-135	+	+
120-145	+	+



Catalogue number	Type	D mm	B mm	B1 mm	d	R mm	z	n _{max}
F04-0653-00AS	FPO-03	160	120-135	145	40	2,7	4	HSS 6000 +
F04-0653-00S	FPO-03	160	120-145	155	40	2,7	4	HSS 6000 +

Cutters with hydro clamping

Cutter or set of cutters with hydraulic clamping system

is designed for professional, very precise machining of solid wood. The tools mounted on hydro sleeve are designed for very precise profiling as well as pre-planing and finishing flat surfaces.

The construction of tools with hydro clamping or hydro sleeve guarantees narrowed tolerance of radial run-out reduced to minimum as fitting tolerance after installing the system on the machine spindle (developing pressure 300 bar) equals to zero, which automatically results in very precise positioning of the tool on the machine spindle. The hydro system which also allows for perfect balancing of the tools, apart from very high machined surface quality, enables working with high cutting and feed speed as well as guarantees significantly increased life of the tool due to even wear of all the blades.

On request, we can suggest and manufacture a proper tool (cutter or set of cutters on a hydro sleeve) for the required type of work, material, parameters and conditions during machining. The set includes set of cutting tools, spacer rings and precise hydro sleeve in a version with a key (available only for $L \leq 110$ mm) or with a pump (for $L \leq 250$).

Advantages:

- precise mounting of the tool on the machine spindle,
- narrowed radial run-out tolerance,
- very high quality of machined material surface,
- increased life of the tool,
- perfect balancing of the tool,
- low vibration level,
- quiet and steady running of the tool,
- ability to work with high speed cutting and feed speed up to 200 m/min.

Hydro cutters (hydro monolith)

We also offer a solution of monolith cutter where the hydro system is an integral part of the cutter's hub. The whole system can't be dismantled which allows for more precise sharpening and balancing of the tool. The sleeve is clamped tight with a pump and loosened with a discharge valve. The valve system is placed on the cutter's hub to enable the operator easy and fast access.

